

# NEXUS

NEW TIMES MAGAZINE

Volume 7, Number 6 OCTOBER – NOVEMBER 2000

PO Box 30, Mapleton Qld 4560, Australia www.nexusmagazine.com

## CONTENTS

LETTERS TO THE EDITOR.....	4	ANCIENT ATOMIC WARFARE—Part 2.....	53
GLOBAL NEWS.....	6	<i>By David Hatcher Childress. Radioactive salt pillars in the Dead Sea and the ruins of vitrified cities in the Indus Valley give credence to descriptions in the Vedic texts of high-tech wars in ancient times.</i>	
<i>News you may have missed: oppressive European secrecy laws; the launch of the "Digital Angel" implant; the CIA's "War on AIDS"; the implications of the UK's new RIP surveillance law...and more.</i>		FORMATIVE FIELDS: UK CROP CIRCLES OF 2000....	61
DeBRIEFINGS: BEHIND THE HEADLINES.....	11	<i>By Andy Thomas. The UK summer 2000 crop circle season yielded a satisfying selection of circular, triangular, diamond-shaped and grid-like patterns as well as some surprising optical illusions.</i>	
<i>A letter by scientists protesting the FDA's soy protein ruling; a dissenting view on AIDS policy; a class action lawsuit on Ritalin fraud; and a report on a healing journey with Brazil's João de Deus.</i>		THE TWILIGHT ZONE.....	67
ON HER MAJESTY'S SECRET SERVICE—Part 1.....	19	<i>We feature John Hogue's report on the Vatican's alleged cover-up of the real Third Secret of Fátima; and highlight recent controversial archaeological finds beneath Lake Titicaca and in Syria and Israel.</i>	
<i>By Stephen Dorril. Britain's Secret Intelligence Service, MI6, is obsessive about high-tech surveillance equipment, intelligence-gathering and security, and its operations are hidden from public scrutiny behind a veil of official secrecy.</i>		REVIEWS—Books.....	71
DECLOAKING PATHOGENS WITH SOUND.....	27	<i>"Physician" by Richard Leviton</i>	
<i>By Sharry Edwards. Analysis of the voice print can reveal the presence of disease-causing pathogens. By receiving inputs of complementary frequencies and harmonics, the body is assisted in fighting these pathogens and restoring health and balance.</i>		<i>"Dogs That Know...Owners Are Coming Home" by Rupert Sheldrake</i>	
SHAKEN BABIES OR VACCINE REACTIONS?.....	35	<i>"The Divine Deception" by Keith Laidler</i>	
<i>By Maureen Hickman. Adverse reactions to vaccines are often mislabelled as Shaken Baby Syndrome; and with SBS court cases becoming more common, medical experts and legal advisers have an ethical responsibility to be well informed.</i>		<i>"The End of Privacy" by Reg Whitaker</i>	
GLOBAL EXPANSION TECTONICS.....	41	<i>"Wellness in Menopause" by Marylyn Meek</i>	
<i>By James Maxlow. Plate tectonics theory has been smashed by modern, global-scale data which suggest that the Earth has been expanding in size particularly since the Early Jurassic period.</i>		<i>"The Crystal Sun" by Robert Temple</i>	
SCIENCE NEWS.....	49	<i>"The Gympie Pyramid Story" by Brett J. Green</i>	
<i>KeelyNet's Jerry Decker presents Robert Calloway's high-efficiency collector circuit; and David W. Allan explains his new theory of gravity and diallel lines.</i>		<i>"Proof of Vedic Culture's Global Existence" by Stephen Knapp</i>	
		<i>"The Shamballa Impacts" by Phillip Lindsay</i>	
		<i>"Remote Viewing Secrets" by Joseph McMoneagle</i>	
		<i>"Our Evolution" by Waldo Vieira, MD</i>	
		<i>"The Jesus Mysteries" by Timothy Freke and Peter Gandy</i>	
		<i>"The Cancer Conspiracy" by Toni Jeffreys, PhD</i>	
		<i>"The Master Key" by Charles F. Haanel</i>	
		<i>"pH: Youthing, Not Ageing" by Harald W. Tietze</i>	
		REVIEWS—Video.....	78
		<i>"What Happened on the Moon?" presented by Ronnie Stronge</i>	
		REVIEWS—Music.....	79
		<i>"Songman" by Nomad</i>	
		<i>"Under Southern Skies" by Tony O'Connor</i>	
		<i>"Dance into Eternity" by Omar Faruk Tekbilek</i>	
		<i>"Feng Shui: The Eightfold Path" by Chinmaya Dunster</i>	
		<i>"Niya Yesh" by Axiom of Choice</i>	
		NEXUS BOOKS, VIDEOS, ADS, SUBS.....	88–95

# NEXUS MAGAZINE

Volume 7, Number 6

OCTOBER – NOVEMBER 2000

PUBLISHED BY

NEXUS Magazine Pty Ltd, ABN 80 003 611 434

EDITOR

Duncan M. Roads

CO-EDITOR

Catherine Simons

ASSISTANT EDITOR/SUB-EDITOR

Ruth Parnell

EDITORS' ASSISTANT

Richard Giles

OFFICE ADMINISTRATOR

Janine Carmichael

CONTRIBUTORS THIS ISSUE

Richard Hood; Stephen Dorril; Sharry Edwards,  
MED; Maureen Hickman; James Maxlow;  
Jerry Decker; Robert Calloway; David W. Allan;  
David Hatcher Childress; Andy Thomas

CARTOONS

Phil Somerville

COVER GRAPHIC

John Cook, jsccook@ozemail.com.au

PRINTING

Warwick Daily News, Queensland, Australia

AUSTRALIAN DISTRIBUTION

Newsagents Direct Distribution

HEAD OFFICE – All Correspondence

PO Box 30, Mapleton, Qld 4560, Australia

Tel: (07) 5442 9280; Fax: (07) 5442 9381

E-mail: editor@nexusmagazine.com

Web page: www.nexusmagazine.com

NEW ZEALAND OFFICE

RD 2, Kaeo, Northland

Tel: +64 (0)9 405 1963; Fax: +64 (0)9 405 1964

E-mail: nexusnz@xtra.co.nz

USA OFFICE - 2940 E. Colfax, #131,

Denver CO 80206

Tel: 303 321 5006; Fax: 603 754 4744

E-mail: nexususa@earthlink.net

UK OFFICE - 55 Queens Rd, East Grinstead, West

Sussex, RH19 1BG. Tel: +44 (0)1342 322854;

Fax: +44 (0)1342 324574

E-mail: nexus@ukoffice.u-net.com

EUROPE OFFICE - PO Box 372, 8250 AJ Dronten,

The Netherlands. Tel: +31 (0)321 380558;

Fax: +31 (0)321 318892

STATEMENT OF PURPOSE

NEXUS recognises that humanity is undergoing a massive transformation. With this in mind, NEXUS seeks to provide 'hard-to-get' information so as to assist people through these changes. NEXUS is not linked to any religious, philosophical or political ideology or organisation.

PERMISSION-TO-REPRODUCE POLICY

While reproduction and dissemination of the information in NEXUS is actively encouraged, anyone caught making a buck out of it, without our express permission, will be in trouble when we catch them!

## Editorial

Welcome to yet another info-packed edition of NEXUS. This issue marks our tenth anniversary of publishing NEXUS Magazine. The first issue published after I purchased the magazine was the October 1990 issue (volume 2, no. 1). In fact, I realised the other day that I have spent 18 years (that's nearly half my entire life so far!) working for alternative news magazines, all of which have had deadlines every two months. I have even evolved my own form of PMT (pre-magazine tension, that is!) according to the rest of the team here.

Our recent articles on the dangers of soy products (NEXUS 7/03, April–May 2000) and the Sai Baba exposé last issue have certainly caused controversy. Judging from the volume and the content of correspondence, it would appear that some readers love it when we attack the "sacred cows" of mainstream society but don't like it when we apply the same standards to the "sacred cows" of alternative society.

When it comes to soy products, there are clearly many, many people who suffer adverse reactions from consuming them. In this issue we reprint, in full, the protest letter written by two FDA "whistleblowers" Daniel Sheehan, PhD, and Daniel Doerge, PhD, which outlines the reasons for their concerns. Bearing in mind that soy products are a multi-billion-dollar transnational industry, I'd say these Daniels are certainly in the lion's den. Their concerns should also be yours, particularly if you consume large amounts of soy products.

The testimonies revealing Sai Baba's sexual misconduct are still the subject of calls, letters and e-mails every day here. Interestingly, not one Sai Baba organisation representative to whom I have spoken has denied any of the allegations. They have *all* sought either to deflect or justify Sai Baba's actions. Needless to say, we have since become aware of more information, including fresh testimonies, all indicating more of the same. Maybe this should serve as a timely reminder that we are responsible for our *own* lives.

The growing debate on the safety and effectiveness of vaccinations has resulted in our commissioning another article linking "shaken baby" deaths with adverse reactions to vaccines. There is also growing attention being given to the adjuvants used in vaccines (adjuvants allegedly act as the "trigger" for the body's immune system). Already, mercury-based adjuvants (e.g., Thimersol) have come under fire in the USA and Europe, and more recently the use of aluminium in vaccines has been the subject of scrutiny (see *Science*, 26 May 2000).

On a completely different subject, we are proud to present the Global Expansion Tectonics article. This postulates that planet Earth has been expanding since ancient times. It suggests that since the Archaean aeon, continents have broken up and dispersed due to crustal extension, in an orderly, pre-determined manner. I hope you find it as fascinating and as stimulating a concept as I do.

This issue also contains our annual focus on the "crop circle" phenomenon. As usual, we are treated to dozens of stunning formations of geometric beauty. As usual, some are hoaxed, and some are, well, unclaimed and unexplained. Colin Andrews, the former UK-based author/researcher now living in the USA, stunned and disappointed circle-watchers this season with a statement reflecting his belief that 80% of formations are hoaxes, with the other 20% being due to the Earth's magnetic field. He presented no evidence to back up either claim, leaving many researchers scratching their heads. Needless to say, the global media gave it plenty of coverage and, once again, millions of people believe the mystery to be "solved". Be sure to visit [www.cropcircleconnector.com](http://www.cropcircleconnector.com) on the Internet to see *all* the formations, in colour, along with more information.

The mystery lives on. Long live the mystery!

Duncan

## WARRANTY AND INDEMNITY

Advertisers upon and by lodging material with the Publisher for publication or authorising or approving of the publication of any material INDEMNIFY the Publisher and its servants and agents against all liability claims or proceedings whatsoever arising from the publication and without limiting the generality of the foregoing to indemnify each of them in relation to defamation, slander of title, breach of copyright, infringement of trademarks or names of publication titles, unfair competition or trade practices, royalties or violation of rights or privacy AND WARRANT that the material complies with all relevant laws and regulations and that its publication will not give rise to any rights against or liabilities in the Publisher, its servants or agents and in particular that nothing therein is capable of being misleading or deceptive or otherwise in breach of the Part V of the Trade Practices Act 1974. All expressions of opinion are published on the basis that they are not to be regarded as expressing the opinion of the Publisher or its servants or agents. Editorial advice is not specific and readers are advised to seek professional help for individual problems.

© NEXUS New Times 2000



# Letters to the Editor ...

## Research into Ionised Urine

Dear Duncan: In 1996 I published my book *Water Medicine*, where I mentioned the use of ionised alkaline and acidic water to treat certain diseases. For the last six years I have been doing studies in this regard, including on the ionisation of urine.

At the first world conference on urine therapy in Goa, India, I spoke to several people about the possibility of ionised urine, but to no avail. Am I the only one in the world researching this subject?

In my book *Urine, The Holy Water*, I did not mention the possibility of ionised urine since I was not ready and was unsure with my brief research at that time.

However, I have some reservations in regard to recycling of the acid-forming minerals and elements in urine—like phosphorus, sulphur and chlorine. Most allopathic drugs contain acid-forming minerals.

Ionisation of urine divides the acid-forming compounds and the alkali-forming compounds. Recycling only the beneficial, alkali-forming ingredients of urine for internal use, and the acid-forming minerals for external use, makes not only a lot of sense but also works better.

Any comments and details about experiences are most welcome. Thank you, and all the best to you.

Harald Tietze, Harald W. Tietze Publishing, Bermagui, NSW, Australia, tel +61 (0)2 6493 4552, fax +61 (0)2 6493 4900, e-mail [tietzepub@sci.net.au](mailto:tietzepub@sci.net.au), website [www.sci.net.au/tietzepub](http://www.sci.net.au/tietzepub)

## Ancient Atomic Warfare

Dear Editor: This theory should really be regarded as fact, to the extent that anything historical or scientific should be called "fact" [see "The Evidence for Ancient Atomic Warfare", Part 1, 7/05]. We have physical evidence (the glass and possibly remaining radioactive isotopes) of ancient nuclear blasts; and we have numerous ancient historical texts from cultures all over the world that describe these wars and the devastating effects. (The ancients considered these warring entities

to be "gods", although these ETs and their descendants are/were no more "god" than anyone else.)

Lana Cantrell's (*The Greatest Story Never Told*) holistic medical investigation of the ancient texts very clearly spelled out what had transpired, including the biological "fall" of man. I was just reading a transcript of Alex Collier's communications with his Andromedan contacts, and their description of these events seemed like a precise summary of Cantrell's findings, with of course additional background info about the warring ET factions.

Peace, Jed Shlackman, [jshlackman@adelphia.net](mailto:jshlackman@adelphia.net)

## Tapping the Energy Grid?

Dear Duncan: Your article on John Bedini's Free-Energy Motor [Science News, 7/04] reminded me of a visit to Ireland—which legend says was an outpost of the Atlantean Empire. In visiting the standing-stone sites, I had the strong impression that these were once remote outposts of a huge system that supplied energy to the whole nation.

In the museums, we saw large collections of bronze horns that had been exhumed near these sites. The horns were always found together with a strange bronze object that was shaped like a light bulb. The object was hollow and did not rattle.

It occurs to me that the horn and the bulb object could have been used together to "create oscillation in the vacuum and then crack it sharply" to obtain the energy stored there. I wonder if your readers have any thoughts on this.

Sally Fallon, [SAFallon@aol.com](mailto:SAFallon@aol.com)

## Sai Baba Exposé Overdue

Dear Duncan: I applaud you for your editorial comments concerning Sai Baba and for including the article in the current edition of NEXUS [7/05]. I could see this happening sooner or later from the evidence passed to me quite a number of years ago. Any attempts I made to make my opinions known were met with slander from SB devotees.

I am a past member of The

Magic Circle and Inner Magic Circle and spent many years as a professional stage magician. I now research, write and lecture on psychic and spiritual science and survival. My new book, just published, is titled *Life Is ForEver* (ISBN 0-9538-0731-2), and I have sent a copy to the NEXUS UK Office.

Keep up the pressure. The Truth will out! My website is [www.jamesw.clara.net](http://www.jamesw.clara.net).

Kind regards, James Webster, [jamesw@clara.net](mailto:jamesw@clara.net)

## The Laetrile Conspiracy

Dear Duncan: I've been reading NEXUS for some years now. I always look forward to another instalment of (for want of a better word) "weirdness". Excellent stuff; keep on keeping on.

I only bought a computer and got an ISP earlier this year, and, like many, I've discovered a cornucopia of otherwise off-limits info, including a lot of stuff about...laetrile. I don't recall ever seeing the "laetrile controversy" covered in NEXUS. This strikes me as a little odd. I try to take an "agnostic" stance (rather than "sceptical") on issues with which I have no personal experience, but there appears to be some compelling evidence for the efficacy of the substance.

Has NEXUS covered this subject in past issues, or will it in the future?

Regards, Rainer Scott, [RainerScott@ukgateway.net](mailto:RainerScott@ukgateway.net)

[Dear Rainer: I haven't covered laetrile simply because I considered it had received adequate exposure during the last two decades. Maybe, however, it is time to do an update. Ed.]

## Tesla Broke the Light Barrier

Dear Sir: In the light of the two recent discoveries of speeds faster than light (Princeton, and Firenze, Italy), I would like to remind your readers that the late Dr Nikola Tesla claimed in 1900 that he managed experimentally to achieve the speeds of 475,000 km/sec and prove that there are speeds in the cosmos even 50 times faster than light.

In the last two years, a few other scientific results have con-

firmed that Dr Tesla was far ahead of his time. If you would like me to write an article about it, please respond to my e-mail. I am a journalist from Belgrade, Yugoslavia, and have written two books about Tesla: *The Inventor for the Third Millennium* and *Tesla's Secret Weapon*.

Sincerely, Aleksandar Milinkovic, [PONIPRES@EUnet.yu](mailto:PONIPRES@EUnet.yu)

## Sensitive Street Lights

Dear Duncan: I am replying to the letter in NEXUS 7/04 by Janusz Kozikowski on sensitive street lights. I am offering myself up for any research you would be willing to conduct into this phenomenon.

I would "blow" 10 to 20 lights, on average, per fortnight. This started (for me) at the end of May this year. I have not taken any detailed notes on the subject, save that it only happens when I am in a contemplative/meditative state. I have talked to several people on the subject and they have experienced a similar phenomenon.

One man I spoke to over the Internet cannot have lightbulbs in his house on anything without their blowing. Another woman also affects street lights.

I believe that it has something to do with the aura and transcendent consciousness. The spiritual aura, heavy in the high-energy layers, reaches out and interacts with the electrical fields in appliances. The people who cause this phenomenon (I am guessing on this next point) have an uncanny ability to read people and a strong intuitive side.

I look forward to being able to read some material on the subject and hopefully shed some light on exactly what causes this.

All my love, Steven Watson, [Emmisary@thevortex.com](mailto:Emmisary@thevortex.com)

## More Street Lights Havoc

Dear Editor: Could you please forward this to Janusz Kozikowski who submitted the letter [7/04] about causing havoc with the street lights?

I, too, have experienced this over many years. For a while it was quite unsettling, but I just learned to live with it. People

# ... more Letters to the Editor

**NB: Please keep letters to approx. 200 to 250 words in length. Ed.**

thought I was making too much of a coincidence—even when they would be with me and I would say, "The light will go out".

I would be interested in communicating with Janusz. I live in Vancouver, British Columbia.

Thank you, Joanne Chartrand, jlchartrand@home.com

## Beyond the Boundaries

Duncan and the crew at NEXUS: You guys are the greatest! I have been interested in "NEXUS-type" subjects from an early age.

Unfortunately, I only discovered the magazine when pursuing alternative health options for my mother-in-law who had cancer. I was very excited to find there was actually a magazine that (as far as I was concerned) was tailor-made for my interests! From that day I have been a loyal subscriber. In five years of reading your magazine, I always look forward to the next issue, much like a child looks forward to Christmas Day.

It is unfortunate that much of the population cannot look at and question their beliefs (or those that have been taught to them) and the mainstream view of our world. There are many people whom I've spoken to, who will follow a certain line of thinking to a certain point where there seems to be a "brick wall" that their mind is incapable of penetrating. I effortlessly pass over that wall and experience all that is beyond the boundaries that many erect for comfort's sake.

Thank you, NEXUS, for continually questioning that which is often taken for granted. It is indeed a great service to mankind.

Aaron Rench, Brisbane, Qld, angieandaaron@myplace.net.au

## Somerville's Cartoons Praised

Dear Editor: I think the Somerville cartoons are some of the most hysterical I have ever read. Has he put out a book of them? How about T-shirts, maybe with the one with the alien and the Hubble telescope—"And no fries"?[7/01]

Please tell Somerville that those cartoons kick butt!

Thanks, Bob Craig, arsis@megsinet.net

## Food for Thought

Dear Editor: Is it legal to call "compounds" such as refined sugar, refined grains and additives "food"? As a successful survivor of depression and the clutches of Prozac, I now eat *food*.

The definition of "food" in *Webster's Dictionary* is "material that nourishes". Refined sugar, refined flour and additives are compounds that do not benefit human consumption. Our bodies were not designed to process refined sugar. Refined sugar depletes the body of minerals and is a known depressant. Refined flour is also a known depressant. Additives can cause rheumatoid arthritis. MSG is a chemical known to cause brain damage. How is it that the FDA can put MSG out on the market under the disguise of "natural food flavouring"?

I now eat *food* and no longer need pharmaceutical drugs. Depression, in my opinion, is an altered state of consciousness. Why should any human being suffer depression, simply because of diet? Depression prevents a person from reaching their full potential and can keep them oppressed and unhappy.

I now eat organic as often as I can. I don't want pesticides, hormones and antibiotics in my food. My water is purified and clear of carcinogens. I abstain from caffeine and alcohol. There is no silver bullet for the consumption of de-natured foods. I exercise several mornings a week and my serotonin levels are set up just fine for the day.

The joke was on me and still is on the rest of the public. The Industrial Revolution brought about compounds that the FDA titles "food". The public goes to the supermarket, thinking that they are buying food that nourishes the body. Wrong. Just about everything is altered and inedible at the supermarket. Perhaps two of the few remaining, most edible choices left at the supermarket are fresh, deep-water fish or farm-raised fish.

Just a reminder that it remains true today that "the buyer beware".

It's sad to see that Codex would

even be an issue in our day and age of advancement and intellectual development. But the reality is that it all seems to come down to big money, not the pursuit of health and enlightenment. Keep looking over your shoulders, folks!

Best wishes, Karen Eipel, Santa Fe, New Mexico, USA

## Pharmaceutical Side-Effects

Dear NEXUS: The following describes an incident at our laboratory in June 2000.

A patient was referred to us for alternative pathology testing. The individual observed had the occupation of dispensing antibiotics in a local hospital pharmacology department for 26 years. The patient inhaled airborne particles each time during the preparation of the 50 to 100 prescriptions daily. The patient had been complaining of health problems for 25 years, with green viscous secretions coming from every orifice including tear ducts. Blood analysis, histology and pathology revealed startling findings. There was a fungal presence of numerous subspecies, far beyond a systemic *Candida* infection. It was part of the DNA.

One of the subspecies was *Mucor raemousis mucedo* which resides in the limbic system, affecting thought patterns (hypothalamus) and hormone (thyroid) balance. The same subspecies has been found by German scientists in people with ADD and ADHD. However, this individual was far beyond this state. To kill the fungus would kill the person. Taking Nilstatin was like taking a lawnmower to a lawn full of weeds. This individual requires large amounts of junk food to survive and has an abnormal desire to infect the opposite sex. Apparently there are others out there.

Dr Greg Fredericks, Nu-Look Biologics, Perth, Western Australia, seln@abacus.com.au

## The GST and NEXUS

Dear NEXUS: I have a couple of comments I would like to make regarding your magazine. For many years now, I have not missed a copy of NEXUS and

have been entertained, informed and inspired by many of your articles.

One thing puzzles me as of late in regard to the GST and NEXUS. In my opinion, the goods and services tax is the greatest imposition on the people's freedom to live their lives without government interference since income taxes were introduced.

A few courageous businesses and individuals have taken a stand against the GST. NEXUS, however, has not only passed the cost on to its customers but seems to have adopted a policy of never even mentioning it. Why the conspiracy of silence?

Yours sincerely, Allan Murphy, Cairns, Queensland, Australia  
[Dear Allan: There is no conspiracy of silence in our not mentioning the GST. I guess I do not see it with the degree of importance that you do. Ed.]

## Elanra Review Clarification

Dear Duncan: Thank you for the review of our new Elanra Portable Ioniser in the August/September edition of NEXUS [7/05]. We are overjoyed to see that you feel as good about this product as we do.

In your review, you mentioned that the battery life was only four hours; this would be the case if we hadn't invented a way of extending the battery life. In fact, using a Duracell 9-volt battery, we get a minimum of 10 hours on maximum output and 20-plus hours when used on the aircraft setting in an aircraft. My wife and I flew from Australia to Los Angeles and back to Australia using the same battery.

Please advise your readers that we will honour the AUD\$395 plus \$15 courier delivery cost, and AUD\$395 plus delivery to the USA, up until the end of this issue [end November 2000].

By the way, you can count us in for your trip to Egypt—very exciting.

Joshua Shaw, Bionic Products Pty Ltd, PO Box 555, Robina, Qld 4226, Australia, tel (07) 5593 1122, fax (07) 5593 0022, website www.negativeions.com

## GROWING DISILLUSIONMENT WITH GOVERNMENTS

Surveys show a sharp decline in confidence in politicians in the United States, Germany, Japan, Britain, Italy and Sweden, with only The Netherlands showing clear evidence of increasing confidence.

The authors of *In Disaffected Democracies: What's Troubling the Trilateral Countries?*, Susan J. Pharr and Robert D. Putnam, analysed the results of surveys conducted in the rich, industrially developed countries. They found that in 1964, only 29% of people in the United States agreed with the statement, "The government is pretty much run by a few big interests looking after themselves". By 1984, that figure had increased to 55%, and by 1998 to 63%.

This loss of confidence is not limited to politicians. In 11 of 14 countries surveyed, the public had also lost confidence in the parliament, the armed forces, the judiciary, the police and the civil service.

The surveys also noted a decline in political participation, with a fall in the membership of political parties and in the proportion of people who turn out to vote. A University of California study, reported in the *Economist* (17 July 1999), showed that in 18 out of 20 rich countries the pro-



portion of the electorate voting was lower than it was in the early 1950s, with a median decline of 10%. In the US, the trend began to show up in the 1960s and has continued ever since.

Australia is not isolated from these trends. According to the World Values Survey, between 1983 and 1995 the proportion of Australians with a great deal of confidence in the federal government fell from 56% to just 26%. The surveys also found that Australians' trust in key institutions such as the media, the public service, the churches and the legal system had decreased.

Since 1995 the trend has continued, with a *Bulletin* Morgan poll (April 1998) finding that only 7% of Australians believed that politicians were honest and ethical, and that 66% were unhappy with the major parties. A similar poll in 1976 found that 19% believed that politicians were honest and ethical. (Source: By Sue Boland, Green Left Weekly, 26 July 2000, website [www.greenleft.org.au](http://www.greenleft.org.au))

## HARK THE HERALDED "DIGITAL ANGEL" IMPLANT

A working prototype of an implant known as "Digital Angel", designed to monitor the physiology and whereabouts of human "wearers", is to be unveiled in October at an invitation-only event in New York City, two months ahead of schedule.

The device, developed by Applied Digital Solutions, Inc. of Palm Beach, Florida, USA, is said to be the first-ever operational combination of bio-sensor technology and Web-enabled wireless telecommunications linked to global positioning satellite location-tracking systems (see Global News, 7/02).

Digital Angel is intended to serve a number of functions. In addition to locating missing persons and monitoring physiological data, the device will be marketed to the world of e-commerce as a means of verifying online consumer identity.

Similar to microchip technologies currently used as electronic ID tags for pets, Digital Angel is a dime-sized implant that is inserted just under the skin. When implanted within a human body, the device is powered electromechanically through the movement of muscles and can be activated either by the "wearer" or by a monitoring facility.

Those attending the event in New York City will see a working, multimedia demonstration of the implant. A miniature sensor device—smaller than a grain of rice and equipped with a tiny antenna—will capture and wirelessly transmit a person's vital body-function data, such as temperature or pulse, to an Internet-integrated ground station. In addition, the antenna will also receive information from the GPS satellite regarding the location of the individual. Both sets of data—medical information and location—will then be wire-

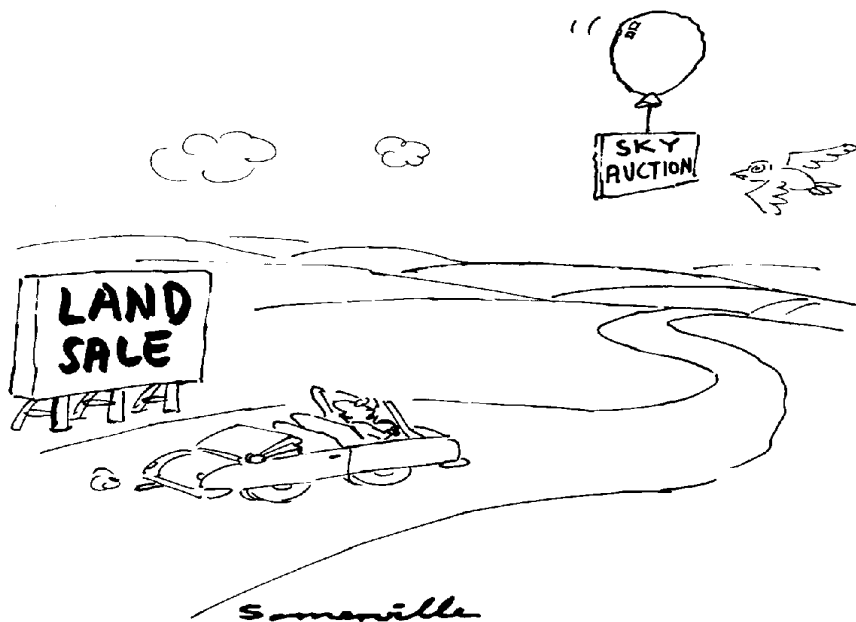

lessly transmitted to the ground station and made available on Web-enabled desktop, laptop or wireless devices.

Research chief Dr Peter Zhou is passionately enthusiastic about the device.

"Digital Angel will be a connection from yourself to the electronic world. It will be your guardian, protector. It will bring good things to you. We will be a hybrid of electronic intelligence and our own soul."

(Sources: ADS press release, 31 July 2000, [www.digitalangel.net](http://www.digitalangel.net); WorldNetDaily, 13 August 2000, [www.worldnetdaily.com/](http://www.worldnetdaily.com/))

## NEW EUROPEAN SECRECY CODE BECOMES LAW

SwEEPING new controls on information, including details of a proposed new European paramilitary police force, have been approved by European Union (EU) governments.

The new EU secrecy code was agreed earlier in August by "written procedure", preventing any debate by the European Parliament. It became part of EU law on 23 August. The code was drawn up in secret by EU security supremo Javier Solana, who is also Secretary-General of the EU Council of Ministers, in cooperation with his successor as NATO Secretary-General, Lord Robertson.

The controls were rushed through despite opposition from the European Ombudsman, Jacob Soderman, who warned that the code could be applied to policy areas presently open to public scrutiny.

Under the Solana plan, all classified documents relating to "security and defence of the Union or one or more of its member states" or to "military or non-military crisis management" will be permanently excluded from public scrutiny.

The blanket secrecy rules will cover proposals to set up a 5,000-strong EU paramilitary police force as well as plans for a rapid reaction force. They could cover all EU discussions on criminal justice, border controls and trade policy.

The code will also enable NATO and non-EU governments to veto the disclosure of EU documents.

However, leaked documents show that the plans go much further than purely military operations. The proposed rapid reaction force could be used to quell "growing violence and destabilising law and order, breaches of the peace, outbreaks of fighting, armed conflicts" and "massive

population movements".

Documents which would have been suppressed under the new controls include minutes of a meeting of paramilitary police from Spain, Portugal, France and Italy in January, at which they discussed the creation of a "European security and investigation force" as a "tool" at the disposal of the EU and NATO.

(Source: By Richard Norton-Taylor, The Guardian, 31 August 2000, [website www.guardian.co.uk](http://www.guardian.co.uk))

## THE SPY IN YOUR POCKET

THE next generation of mobile phones will make it much easier for the police to carry out covert surveillance of citizens, say UK civil liberties campaigners.

They warn that the combination of location-revealing technology built into the phones and rights given to the police under the UK Regulation of Investigatory Powers (RIP) Act means that the owners of such phones can and will be watched. They are now advising people that using one of the new phones might make it hard for them to maintain their privacy.

In recognition of the implications, phone companies are working on ways to allow clients to conceal where they are at the touch of a button.

Although existing GSM handsets can be used as location devices, they typically only give a fix to within a couple of hundred metres. This accuracy can be improved if handsets are fitted with special

software that give a fix to within 50 metres of their actual position. Newer mobile phone technologies such as the General Packet Radio Services (GPRS) and Universal Mobile Telecommunications Services (UMTS) have even more accurate locating systems built in. GPRS services are due to become widely available later this year, and UMTS telephone networks are due to be switched on in 2002.

But Caspar Bowden, director of the Foundation for Information Policy Research, warns that the newly passed Regulation of Investigatory Powers Act could allow for the data to be used for a more sinister purpose. He says the RIP Act regards the information used to locate phones as "communications data" and that police do not need a warrant to obtain it. The police could thus use this information to conduct covert surveillance of anyone using such a phone.

(Source: By Mark Ward, BBC News Online, 14 August 2000, <http://news.bbc.co.uk/hi/english/sci/tech/>)

## DOCTORS, THE THIRD LEADING CAUSE OF DEATHS IN THE US

THE US population does not have anywhere near the best health in the world. Of 13 countries in a recent comparison, the United States ranks an average of 12th (second from the bottom) for 16 available health indicators.

Countries in order of their average ranking on the health indicators (with the first



being the best) are: Japan, Sweden, Canada, France, Australia, Spain, Finland, The Netherlands, UK, Denmark, Belgium, USA and Germany.

US estimates of the combined effect of errors and adverse effects that occur because of iatrogenic damage not associated with recognisable error include:

- 12,000 deaths/year from unnecessary surgery;
- 7000 deaths/year from medication errors in hospitals;
- 20,000 deaths/year from other errors in hospitals;
- 80,000 deaths/year from nosocomial infections in hospitals;
- 106,000 deaths/year from non-error, adverse effects of medications.

These total 225,000 deaths per year from iatrogenic causes.

It should be noted that most of the data is derived from studies of hospitalised patients, and that these estimates are for deaths only and do not include adverse effects that are associated with disability or discomfort. If the higher estimates are used, the deaths due to iatrogenic causes would range from 230,000 to 284,000 per year.

In any case, 225,000 deaths per year from iatrogenic causes constitutes the third leading cause of death in the United States,

after deaths from heart disease and cancer. (Source: JAMA 284[4], 26 July 2000, <http://jama.ama-asan.org/issues/>)

## CIA OVERSEES "WAR ON AIDS"

On 30 April, the *Washington Post* announced a National Security Agency (NSA) move to place AIDS science, and all public health agencies conducting it, under the command of the Central Intelligence Agency (CIA).

Curiously, this move follows South African President Thabo Mbeki's decision to include the testimonies of "dissident" scientists in his country's review of HIV/AIDS treatment practices and the epidemic's origin.

President Clinton, advised by the National Intelligence Council (NIC) to formally declare global AIDS a US "national security threat", signed this policy into law. The action foreshadows the likely persecution, if not incarceration or assassination, of "dissident" AIDS scientists.

The CIA warned in its report to the President and press: "The persistent infectious disease burden is likely to aggravate and, in some cases, may even provoke economic decay, social fragmentation, and political destabilization in the hardest-hit countries..."

The study defined "instability" as revolutionary wars, ethnic wars, genocides and disruptive regime transitions. Dramatic declines in life expectancy, the study said, are the strongest risk factor for "such threats to national security".

Killing two birds with one stone—promoting vaccination and medication—the propagandist report stated that such threats and "deterioration" might be followed by "limited improvement...owing to better prevention and control efforts, new drugs, and vaccines".

Given the potentially grave socio-economic,

political and now military implications of uncovering a vaccine industry-linked cause of AIDS, future publications and open dialogue regarding this hypothesis in the mainstream and scientific media may be increasingly difficult to achieve.

(Source: By Dr Leonard Horowitz, Idaho Observer, USA, July 2000)

## BRITISH DRUG-REGULATOR DOCTORS IN SHARES SCAM

Many of the experts who advise the UK government on the safety of medicines have shares in the drug companies which benefit from their decisions.

According to UK media reports, more than two-thirds of the doctors and academics who serve on committees of the Medicines Control Agency (MCA) have investments in the pharmaceutical industry or benefit from drug company cash.

Some doctors have huge shareholdings worth more than £100,000 in major companies such as SmithKline Beecham and AstraZeneca. Many others are dependent on consultancies, fees and research grants from the industry giants.

Nicholas Harvey, the Liberal Democrats' health spokesman, has called for a tightening-up of the regulations governing the advisers' interests and has condemned the secrecy in the committees' meetings, which are all held behind closed doors.

The *Sunday Express* found that more than 170 of the MCA's 248 members have financial links with pharmaceutical companies. A total of 42 own shares in a variety of companies.

(Source: By Jonathan Calvert and Lucy Johnston, *Sunday Express*, London, 6 August 2000, website [www.lineone.net/express/](http://www.lineone.net/express/))

## LIMITED DEBT RELIEF MAY MAKE POOR NATIONS WORSE OFF

International efforts to cut the debts of the world's poorest countries are leaving some of these paying tens of millions of dollars more to their Western creditors, says Oxfam.

The aid agency described the debt relief package which the World Bank and International Monetary Fund are offering Zambia, one of the most impoverished countries in Africa, as a "fraud".

Confidential papers from the IMF, obtained by Oxfam, show that Zambia's interest payments are set to rise from US\$136m (£91m) in 1999 to \$235m in 2002, even though it is expected to enter



**"I'll have an entrée of emulsifiers followed by some lightly grilled mercury, with a side order of gently oxidised preservatives and the lady will have anything that's genetically modified."**



the West's official debt relief program in October this year. The increase is due to payments falling due on a large IMF loan.

Oxfam has called for the Fund to write-off all the money owed to it by Zambia over the next few years, instead of offering the country limited debt relief.

"The ultimate yardstick for measuring debt sustainability must be human need, rather than abstract financial indicators during creditor horse-trading," said David Bryer, Oxfam's director.

Oxfam's figures show that in six African countries—Mali, Burkina Faso, Tanzania, Mozambique, Zambia and Malawi—debt payments will outstrip spending on basic education even after the countries have graduated from the debt relief program.

(Source: The Guardian, 21 August 2000)

## NATO DOES ABOUT-TURN ON KOSOVO DEATH TOLL

Findings by forensic teams from the International Criminal Tribunal for the former Yugoslavia (ICTY) in The Hague have forced NATO to admit that, at most, 3,000 people were killed by Yugoslav forces in Kosovo during the conflict.

Last year, NATO charged that Yugoslav forces had massacred at least 10,000 people. NATO spokespeople implied that as many as 500,000 supposedly "missing" people had also been killed.

NATO has now been forced to admit that in effect it waged a propaganda war to win support for its own illegal intervention that killed over 3,000 Yugoslavs, about one-third of them children.

(Source: Workers World newspaper, 31 August 2000, [www.workers.org](http://www.workers.org))

## BRITISH AIRCRAFT BOMBED OUT IN KOSOVO CONFLICT

The UK Government stands accused of trying to suppress a report showing that only 3 out of 150 unguided, high-explosive bombs dropped by British aircraft in the Kosovo conflict last year were confirmed as hitting their targets.

The report, produced by the Defence Evaluation and Research Agency of the Ministry of Defence, also showed that only 40% of all bombs dropped by RAF aircraft in the campaign hit their target.

This raises the prospect that civilian casualties and damage to property have been seriously underestimated.

(Source: The Independent, 15 August 2000, [www.independent.co.uk/news/World/Europe/2000-08/kosovo150800.shtml](http://www.independent.co.uk/news/World/Europe/2000-08/kosovo150800.shtml))

## THE SPY IN YOUR SERVER

Governments all over the world have become embroiled in controversy about electronic surveillance of the Internet. In the USA, a political storm has arisen over a new FBI Internet-tapping system, code-named *Carnivore*. In Britain, the Regulation of Investigatory Powers (RIP) Act now extends telephone-tapping powers to cover Internet service providers (ISPs), and allows the government to arrange indiscriminate tapping or e-mail interception for foreign police forces and security agencies.

Several worldwide factors lie behind the RIP Bill's introduction. The most important of these is to ensure compliance with the conditions of a new American-sponsored international regime of communications interception, whereby law enforcement agencies in one country can quickly arrange for selective monitoring of another country's telecoms traffic in the course of a criminal or intelligence investigation.

Known under the even more unwieldy title of International User Requirements for Lawful Interception of Communications, these came into force secretly within the European Union in 1995. In total, 19 countries—the 15 EU states plus the United States, Australia, Canada and New Zealand—have signed the plan. In short, the EU and members of the NSA-led worldwide UKUSA electronic eavesdropping system, of which *Echelon* is an integral part, have all signed up.

In The Netherlands, the Dutch security service BVD admitted in late July that it has been collecting e-mails sent abroad by companies. In The Hague, laws are being prepared to allow the Justice Ministry to tap into e-mail and subscriber records, scan messages and mobile phone calls, and track users' movements. The Australian government has already passed laws allowing security agents to attack and modify computers secretly to obtain information. Many other governments have similar schemes in the pipeline.

These developments are no coincidence, but the direct result of secret planning over seven years by an international co-ordinating group set up by the FBI—after Congress twice refused to extend its telephone-tapping powers for digital networks. Under the innocuous title of the International Law Enforcement Telecommunications Seminar (ILETS), the group has met annually to plan and lobby for telecommunications systems to be made "interception-friendly".

The work of ILETs first came to light in late 1997 when a British researcher, Tony Bunyan, revealed collaboration between EU staff and the FBI over many years. Details of plans to compel ISPs all over the world to install secret Internet interception "black boxes" in their premises appeared in *Online* last year.

In July, the European Parliament appointed 36 MEPs to lead a year-long investigation into *Echelon*—the code-name for a mainly US system for monitoring traffic on commercial communications satellites. *Echelon* has become common parlance for the worldwide electronic eavesdropping or signals intelligence (SIG-INT) network, run by the Government Communications Headquarters (GCHQ) together with the US National Security Agency (NSA). The inquiry will ask if the rights of European citizens are adequately protected and will ascertain whether European industry is being put at risk by the global interception of communications.

Electronic eavesdropping has become a battleground between the US and Russia. The Russian-American Trust and Cooperation Act of 2000, passed on 19 July, stops President Clinton rescheduling or writing-off billions of dollars of Russian debts unless a Russian spy base in Cuba is "permanently closed". This base at Lourdes, located on leased land near Havana, was the former Soviet Union's most important intelligence facility. It uses *Echelon*-type systems to collect data from telephone calls and satellite links covering the US, and allegedly provides "between 60% and 70% of all Russian intelligence data about the US".

The White House wants to stop the campaign to close Lourdes because other countries might then ask the US to close down its identical bases. Documents suggest the US would particularly fear the Lourdes effect spreading to Britain, Germany and Australia, where the NSA operates large sites. Its station at Menwith Hill, Yorkshire, England, is the largest electronic intelligence base in the world.

(Sources: By Duncan Campbell, The Guardian, London, 10 August 2000, [www.guardianunlimited.co.uk/online/](http://www.guardianunlimited.co.uk/online/); Intelligence, France, no. 370, 10 July 2000, [www.blythe.org/Intelligence](http://www.blythe.org/Intelligence))



# deBriefings

## SCIENTISTS PROTEST FDA'S SOY PROTEIN RULING

Our publication of "Tragedy and Hype", an article by Sally Fallon and Mary Enig on the politics and health implications of soy products (see NEXUS 7/03, April–May 2000), had quite an impact on readers, particularly those who had been consuming soy for many years without realizing that it was related to their inexplicable health problems.

The article mentioned the work of Daniel Sheehan, PhD, and Daniel Doerge, PhD, from the US Food and Drug Administration's National Center for Toxicological Research, who wrote a protest letter ahead of a new FDA ruling "authorizing the use, on food labels and in food labeling, of health claims on the association between soy protein and reduced risk of coronary heart disease (CHD)". The FDA had come to the conclusion that "soy protein included in a diet low in saturated fat and cholesterol may reduce the risk of CHD by lowering blood cholesterol levels". However, the FDA disregarded contradictory evidence, and the new ruling came into effect on 26 October 1999.

Drs Sheehan and Doerge were interviewed for the ABC's 20/20 program in the US, broadcast on 9 June and since screened widely around the world. The program looked at the controversy over the safety of soy products as a healthy source of protein, focusing on the relationship between soy and breast cancer in women, accelerated brain ageing in men and developmental disorders in infants. The two researchers told 20/20 that they had tried in vain to stop the FDA's recommendation because it could be misinterpreted as a broader general endorsement beyond solely having benefits for the heart. (For program summary, see [http://abc-news.go.com/onair/2020/2020\\_000609\\_soy\\_feature.html](http://abc-news.go.com/onair/2020/2020_000609_soy_feature.html).)

The following is the text of their letter dated 18 February 1999. (Please note that while it does refer to a number of studies involving animals, we would like to make it clear that NEXUS in no way condones or supports the efficacy, validity or morality of animal experimentation or vivisection.)

DEPARTMENT OF HEALTH AND HUMAN SERVICES  
Public Health Service Food and Drug Administration  
National Center For Toxicological Research  
Jefferson, Ark. 72079-9502

Daniel M. Sheehan, PhD  
Director, Estrogen Base Program  
Division of Genetic and Reproductive Toxicology  
and

Daniel R. Doerge, PhD  
Division of Biochemical Toxicology

February 18, 1999

Dockets Management Branch (HFA-305)  
Food and Drug Administration  
Rockville, MD 20852

To whom it may concern,

We are writing in reference to Docket #98P-0683; "Food Labeling: Health Claims; Soy Protein and Coronary Heart Disease". We oppose this health claim because there is abundant evidence that some of the isoflavones found in soy, including genistein and equol, a metabolite of daidzein, demonstrate toxicity in estrogen-sensitive tissues and in the thyroid. This is true for a number of species, including humans. Additionally, the adverse effects in humans occur in several tissues and, apparently, by several distinct mechanisms.

Genistein is clearly estrogenic; it possesses the chemical structural features necessary for estrogenic activity (Sheehan and Medlock, 1995; Tong et al., 1997; Miksicek, 1998) and induces estrogenic responses in developing and adult animals and in adult humans. In rodents, equol is estrogenic and acts as an estrogenic endocrine disrupter during development (Medlock et al., 1995a,b). Faber and Hughes (1993) showed alterations in LH regulation following developmental treatment with genistein. Thus, during pregnancy in humans, isoflavones *per se* could be a risk factor for abnormal brain and reproductive tract development. Furthermore, pregnant rhesus monkeys fed genistein had serum estradiol levels 50–100 per cent higher than the controls in three different areas of the maternal circulation (Harrison et al., 1998). Given that the rhesus monkey is the best experimental model for humans, and that a woman's own estrogens are a very significant risk factor for breast cancer, it is unreasonable to approve the health claim until complete safety studies of soy protein are conducted.

Of equally grave concern is the finding that the fetuses of genistein-fed monkeys had a 70 per cent higher serum estradiol level than did the controls (Harrison et al., 1998). Development is recognized as the most sensitive life-stage for estrogen toxicity because of the indisputable evidence of a very wide variety of frank malformations and serious functional deficits in experimental animals and humans. In the human population, DES exposure stands as a prime example of adverse estrogenic effects during development. About 50 per cent of the female offspring and a smaller fraction of male offspring displayed one or more malformations in the reproductive tract, as well as a lower prevalence (about one in a thousand) of malignancies. In adults, genistein could be a

UNTAPPED AD SPACE #1

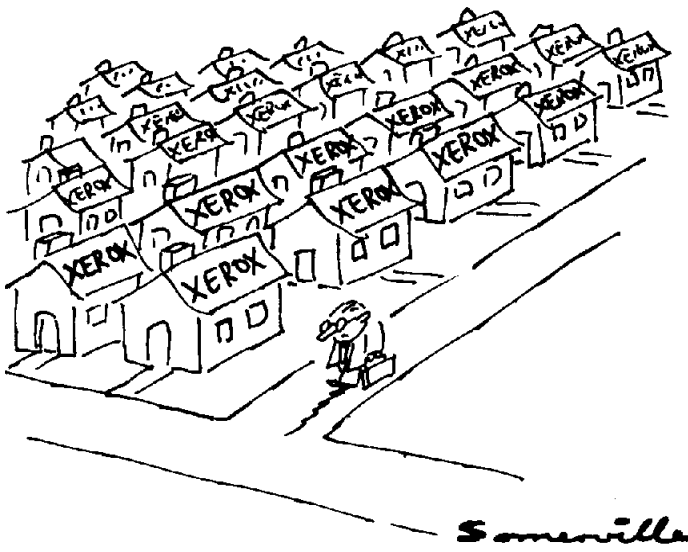

# deBriefings

risk factor for a number of estrogen-associated diseases.

Even without the evidence of elevated serum estradiol levels in rhesus fetuses, potency and dose differences between DES and the soy isoflavones do not provide any assurance that the soy protein isoflavones *per se* will be without adverse effects. First, calculations based on the literature show that doses of soy protein isoflavones used in clinical trials which demonstrated estrogenic effects were as potent as low but active doses of DES in rhesus monkeys (Sheehan, unpublished data). Second, we have recently shown that estradiol shows no threshold in an extremely large dose-response experiment (Sheehan et al., 1999), and we subsequently have found 31 dose-response curves for hormone-mimicking chemicals that also fail to show a threshold (Sheehan, 1998a). Our conclusions are that no dose is without risk; the extent of risk is simply a function of dose. These two features support and extend the conclusion that it is inappropriate to allow health claims for soy protein isolate.

Additionally, isoflavones are inhibitors of the thyroid peroxidase which makes T3 and T4. Inhibition can be expected to generate thyroid abnormalities, including goiter and autoimmune thyroiditis. There exists a significant body of animal data that demonstrates goitrogenic and even carcinogenic effects of soy products (Kimura et al., 1976). Moreover, there are significant reports of goitrogenic effects from soy consumption in human infants (Van Wyk et al., 1959; Hydovitz, 1960; Shepard et al., 1960; Pinchers et al., 1965; Chorazy et al., 1995) and adults (McCarrison, 1933; Ishizuki et al., 1991). Recently, we have identified genistein and daidzein as the goitrogenic isoflavonoid components of soy and defined the mechanisms for inhibition of thyroid peroxidase (TPO)-catalyzed thyroid hormone synthesis *in vitro* (Divi et al., 1997; Divi et al., 1996). The observed suicide inactivation of TPO by isoflavones, through covalent binding to TPO, raises the possibility of neoantigen formation and because anti-TPO is the principal autoantibody present in autoimmune thyroid disease. This hypothetical mechanism is consistent with the reports of Fort et al. (1986, 1990) of a doubling of risk for autoimmune thyroiditis in children who had received soy formulas as infants compared to infants receiving other forms of milk.

The serum levels of isoflavones in infants receiving soy formula are about five times higher than in women receiving soy supplements who show menstrual cycle disturbances including an increased estradiol level in the follicular phase (Setchell, et al., 1997). Assuming a dose-dependent risk, it is unreasonable to assert that the infant findings are irrelevant to adults who may consume smaller amounts of isoflavones. Additionally, while there is an unambiguous biological effect on

menstrual cycle length (Cassidy et al., 1994), it is unclear whether the soy effects are beneficial or adverse. Furthermore, we need to be concerned about transplacental passage of isoflavones, as the DES case has shown us that estrogens can pass the placenta. No such studies have been conducted with genistein in humans or primates. As all estrogens which have been studied carefully in human populations are two-edged swords in humans (Sheehan and Medlock, 1995; Sheehan, 1997), with both beneficial and adverse effects resulting from the administration of the same estrogen, it is likely that the same characteristic is shared by the isoflavones. The animal data is also consistent with adverse effects in humans.

Finally, initial data from a robust (7,000 men), long-term (30+ years) prospective epidemiological study in Hawaii showed that Alzheimer's disease prevalence in Hawaiian men was similar to European-ancestry Americans and to Japanese (White et al., 1996a). In contrast, vascular dementia prevalence is similar in Hawaii and Japan and both are higher than in European-ancestry Americans. This suggests that common ancestry or environmental factors in Japan and Hawaii are responsible for the higher prevalence of vascular dementia in these locations. Subsequently, this same group showed a significant dose-dependent risk

**Subsequently, this same group showed a significant dose-dependent risk (up to 2.4-fold) for development of vascular dementia and brain atrophy from consumption of tofu, a soy product rich in isoflavones.**

(up to 2.4-fold) for development of vascular dementia and brain atrophy from consumption of tofu, a soy product rich in isoflavones (White et al., 1996b). This finding is consistent with the environmental causation suggested from the earlier analysis, and provides evidence that soy (tofu) phytoestrogens cause vascular dementia. Given that estrogens are important for maintenance of brain function in women, that the male brain contains aromatase, the enzyme that converts testosterone to estradiol, and that isoflavones inhibit this

enzymatic activity (Irvine, 1998), there is a mechanistic basis for the human findings. Given the great difficulty in discerning the relationship between exposures and long-latency adverse effects in the human population (Sheehan, 1998b) and the potential mechanistic explanation for the epidemiological findings, this is an important study. It is one of the more robust, well-designed prospective epidemiological studies generally available. We rarely have such power in human studies, as well as a potential mechanism, and thus the results should be interpreted in this context.

Does the Asian experience provide us with reassurance that isoflavones are safe? A review of several examples led to the conclusion, "Given the parallels with herbal medicines with respect to attitudes, monitoring deficiencies and the general difficulty of detecting toxicities with long latencies, I am unconvinced that the long history of apparent safe use of soy products can provide confidence that they are indeed without

# deBriefings

risk" (Sheehan, 1998b). It should also be noted that the claim on p. 62978 that soy protein foods are GRAS [Generally Recognized As Safe] is in conflict with the recent return by CFSAN [Center for Food Safety and Applied Nutrition, FDA] to Archer Daniels Midland of a petition for GRAS status for soy protein because of deficiencies in reporting adverse effects in the petition. Thus GRAS status has not been granted. Linda Kahl can provide you with details. It would seem appropriate for FDA to speak with a single voice regarding soy protein isolate.

Taken together, the findings presented here are self-consistent and demonstrate that genistein and other isoflavones can have adverse effects in a variety of species, including humans. Animal studies are the front line in evaluating toxicity as they predict, with good accuracy, adverse effects in humans. For the isoflavones, we additionally have evidence of two types of adverse effects in humans, despite the very few studies that have addressed this subject. While isoflavones may have beneficial effects at some ages or circumstances, this cannot be assumed to be true at all ages. Isoflavones are like other estrogens in that they are two-edged swords, conferring both benefits and risk (Sheehan and Medlock, 1995; Sheehan, 1997). The health

labeling of soy protein isolate for foods needs to be considered just as would the addition of any estrogen or goitrogen to foods, which are bad ideas.

Estrogenic and goitrogenic drugs are regulated by FDA, and are taken under a physician's care. Patients are informed of risks, and are monitored by their physicians for evidence of toxicity. There are no similar safeguards in place for foods, so the public will be put at potential risk from soy isoflavones in soy protein isolate without adequate warning and information.

Finally, NCTR is currently conducting a long-term multigeneration study of genistein administered in feed to rats. The analysis of the dose-range-finding studies are near-complete or complete now. As preliminary data, which is still confidential, may be relevant to your decision, I suggest you contact Dr Barry Delclos at the address on the letterhead, or e-mail him.

Sincerely,  
Daniel M. Sheehan  
Daniel R. Doerge

Enclosures  
cc: Dr Bernard Schwetz, Director, NCTR  
cc: Dr Barry Delclos

## References

- Cassidy, A., Bingham, S. and Setchell, K.D.R., "Biological effects of soy protein rich in isoflavones on the menstrual cycle of premenopausal women", *Am. J. Clin. Nutr.* 60:333-340, 1994.
- Chorazy, P.A., Himelhoch, S., Hopwood, N.J., Greger, N.G. and Postellon, D.C., "Persistent hypothyroidism in an infant receiving a soy formula: Case report and review of the literature", *Pediatrics* 148-150, 1995.
- Divi, R.L., Chang, H.C. and Doerge, D.R., "Identification, characterization and mechanisms of anti-thyroid activity of isoflavones from soybean", *Biochem. Pharmacol.* 54:1087-1096, 1997.
- Divi, R.L. and Doerge, D.R., "Inhibition of thyroid peroxidase by dietary flavonoids", *Chem. Res. Toxicol.* 9:16-23, 1996.
- Fort, P., Lanes, R., Dahlem, S., Reeker, B., Weyman-Daum, M., Pugliese, M. and Lifshitz, F., "Breast feeding and insulin-dependent diabetes mellitus in children", *J. Am. Coll. Nutr.* 5:439-441, 1986.
- Fort, P., Moses, N., Fasano, M., Goldberg, T. and Lifshitz, F., "Breast and soy-formula feedings in early infancy and the prevalence of autoimmune thyroid disease in children", *J. Am. Coll. Nutr.* 9:164-167, 1990.
- Harrison, R.M., Phillippi, P.P. and Henson, M.C., "Effects of genistein on estradiol production in pregnant rhesus monkeys (*Macaca mulatta*)", *Am. J. Primatology* 45:183, 1998.
- Hydovitz, J.D., "Occurrence of goiter in an infant on a soy diet", *New Eng. J. Med.* 262:351-353, 1960.
- Irvine, C.H.G., Fitzpatrick, M.G. and Alexander, S.L., "Phytoestrogens in soy-based infant foods: Concentrations, daily intake, and possible biological effects", *Proc. Soc. Exp. Biol. Med.* 217:247-253, 1998.
- Ishizuki, Y., Hirooka, Y., Murata, Y. and Togasho, K., "The effects on the thyroid gland of soybeans administered experimentally to healthy subjects", *Nippon Naibunpi gakkai Zasshi* 67:622-629, 1991.
- Kimura, S., Suwa, J., Ito, B. and Sate, H., "Development of malignant goiter by defatted soybean with iodine-free diet in rats", *Gann.* 67:763-765, 1976.
- Levy, J.R., Faber, F.A., Ayyash, L. and Hughes, C.L., "The effect of prenatal exposure to phytoestrogen genistein on sexual differentiation in rats", *Proc. Soc. Exp. Biol. Med.* 208:60-66, 1995.
- McCarrison, R., "The goitrogenic action of soybean and groundnut", *Indian J. Med. Res.* 21:179-181, 1933.
- Medlock, K.L., Branham, W.S. and Sheehan, D.M., "The effects of phytoestrogens on neonatal rat uterine growth and development", *Proc. Soc. Exp. Biol. Med.* 208:307-313, 1995.
- Medlock, K.L., Branham, W.S. and Sheehan, D.M., "Effects of coumestrol and equol on the developing reproductive tract of the rat", *Proc. Soc. Exp. Biol. Med.* 208:67-1, 1995.
- Miksicek, R.J., "Estrogenic flavonoids: Structural requirements for biological activity", *Proc. Soc. Exp. Biol. Med.* 208:44-50, 1995.
- Pinchers, A., MacGillivray, M.H., Crawford, J.D. and Freeman, A.G., "Thyroid refractoriness in an athyreotic cretin fed soybean formula", *New Eng. J. Med.* 265:83-87, 1965.
- Setchell, K.D.R., Zimmer-Nechemias, L., Cai, J. and Heubi, J.E., "Exposure of infants to phytoestrogens from soy-based infant formula", *Lancet* 350:23-27, 1997.
- Sheehan, D.M., "Literature analysis of no-threshold dose-response curves for endocrine disruptors", *Teratology* 57:219, 1998a.
- Sheehan, D.M., "Herbal medicines and phytoestrogens: risk-benefit considerations", *Proc. Soc. Exp. Biol. Med.* 217:379-385, 1998b.
- Sheehan, D.M., "Isoflavone content of breast milk and soy formulas: Benefits and risks", *Clin. Chem.* 43:850, 1997.
- Sheehan, D.M. and Medlock, K.L., "Current issues regarding phytoestrogens", *Polyphenols Actualities* 13:22-24, 1995.
- Sheehan, D. M., Willingham, E., Gaylor, D., Bergeron, J. M. and Crews, D., "No threshold dose for oestradiol-induced sex reversal of turtle embryos: How little is too much?" *Environmental Health Perspectives*, February 1999.
- Shepard, T.H., Pyne, G.E., Kirschvink, J.F. and McLean, C.M., "Soybean goiter", *New Eng. J. Med.* 262:1099-1103, 1960.
- Tong, W., Perkins, R., Xing, L., Welsh, W.J. and Sheehan, D.M., "QSAR models for binding of estrogenic compounds to estrogen receptor alpha and beta subtypes", *Endo.* 138:4022-4025, 1997.
- Van Wyk, J.J., Arnold, M.B., Wynn, J. and Pepper, F., "The effects of a soybean product on thyroid function in humans", *Pediatrics* 24:752-760, 1959.
- White, L., Petrovitch, H., Ross, G.W. and Masaki, K.H., "Association of mid-life consumption of tofu with late life cognitive impairment and dementia: The Honolulu-Asia Aging Study", *The Neurobiol. of Aging* 17(suppl. 4):S121, 1996a.
- White, L., Petrovitch, H., Ross, G.W., Masaki, K.H., Abbot, R.D., Teng, E.L., Rodriguez, B.L., Blanchette, P.L., Havlik, R.J., Wergowske, G., Chiu, D., Foley, D.J., Murdaugh, C. and Curb, J.D., "Prevalence of dementia in older Japanese-American men in Hawaii", *JAMA* 276:955-960, 1996b.

# deBriefings

## A DISSENTING VIEW ON AIDS POLICY

by Michael P. Wright © 2000

**A**s a former AIDS research grant recipient, I wish to praise South African President Thabo Mbeki for his courage in having publicly declared his willingness to listen to scientists who challenge AIDS orthodoxy.

For nine years, beginning in 1987, I was involved professionally in AIDS/HIV research. During the 1990s, I was awarded two federal grants for this work by the Small Business Innovation Research program of the US National Cancer Institute. By the end of this period, I had become sceptical about official beliefs concerning AIDS.

My project was to design computer software that assessed risk for current HIV infection. After computing the probability of infection by incorporating the anonymous user's answers into a detailed history interview conducted in privacy, the software makes a recommendation about whether the individual should have an HIV antibody test.

In order to win these grants, I had to review the epidemiologic literature to arrive at plausible measures of HIV transmission risk for different kinds of sexual conduct and at reasonable estimates of HIV infection prevalence within various US population groups.

From this research, I concluded that there was absolutely no reason to fear a heterosexual HIV epidemic sustained by the practice of vaginal sex in the United States.

Although numerous studies have demonstrated the enormously low possibility of a heterosexual HIV epidemic, the Centers for Disease Control (CDC) chose to ignore them and launched a fraudulent campaign of fear to convince the majority of the American public that sexually active people are at significant risk of contracting HIV.

The scare campaign was initiated in the late 1980s, and was nothing more than a political strategy to stir up popular support for elevated government spending for various AIDS programs, including pursuit of the elusive dream of miracle cures. Pharmaceutical companies have enjoyed handsome benefits from this endeavour, and now seek to expand their enterprises in South Africa and other Third World nations. There is a large body of literature which supports the conclusion that the possibility of a heterosexual HIV epidemic is enormously low. [Referenced examples deleted due to space considerations; contact us for these if required, or see the website listed at the end of this article. Ed.]

In one of the more honest moments of reporting by the mainstream American press, the *Wall Street Journal* exposed the political nature of the scare campaign in a long article published on May 1, 1996. The *Journal* described the creation of the CDC's "marketing campaign" to spread the belief in universality of risk for AIDS. The article reported that federal funding for AIDS-related medical research grew to US\$1.65 billion in 1996 from \$341 million in 1987, while the CDC's prevention dollars grew to \$584 million from \$136 million. Interestingly, as shown by the

CDC's own published numbers, the HIV prevalence within the vast population they were intending to frighten was actually declining as the scare propaganda was escalated.

As I observed the growing credibility gap between the perception manufactured by the scare campaigners and the reality described in the scientific press, I became open to arguments attacking other elements in the officially promoted belief system about AIDS. In plain terms, one might ask: if they would lie as shamelessly as they have about heterosexual risk, could they be trusted to be honest about other aspects of AIDS?

Robert Root-Bernstein, a Michigan State physiologist and the author of *Rethinking AIDS* (Free Press, 1993), was the first sceptical writer to influence me to begin questioning the view that HIV is the sole cause of AIDS. In a *Wall Street Journal* guest editorial (March 17, 1993), he pointed out that AIDS had remained within specific risk groups: gay men and "an ever-growing population of urban, drug-addicted, poverty-ridden, malnourished, hopeless and medically deprived people".

Root-Bernstein further emphasised that those who suffer from

AIDS "have many additional immune-suppressive factors at work for them that predispose them to disease". His list of examples included semen-induced autoimmunity following unprotected anal sex, blood transfusions, multiple concurrent infections, both recreational and pharmaceutical drug use, malnutrition and anaemia.

His opinion was that HIV does not explain AIDS in the absence of a co-factor. It follows that eliminating the other risk factors is the plausible strategy for combatting AIDS, instead of treatment with toxic antiviral drugs.

In the foreword to *Inventing the AIDS Virus* (Regnery Publishing, 1997) by prominent AIDS dissenter Peter M. Duesberg, Nobel laureate Kary Mullis reports his failure to discover a single scientific publication demonstrating that HIV is the cause of AIDS.

The official definition of "AIDS" has been an evolving political drama whose script has been written by bureaucratic operatives scheming on maximising advantage for their agencies. In the United States, there have been four official AIDS definitions since 1983. Dr Duesberg says: "Every time the CDC needs higher rates of new AIDS cases, it expands that definition once again, and more diseases are reclassified into the syndrome."

In Africa, an altogether different definition is used. Created by the World Health Organization, it does not even require that presence of HIV be detected in order to diagnose an "AIDS" case.

Given this state of affairs, a more plausible statement of a tenable scientific hypothesis would be: what factors explain serious illness and mortality in those who have been labelled "AIDS" patients? Are there, on published record, any cases of such patients for whom all proposed causes of immunosuppression, other than HIV infection, have been contradicted by evidence?

(Source: by Michael P. Wright, San Francisco Chronicle, May 24, 2000; [www.lightparty.com/Health/Health.html](http://www.lightparty.com/Health/Health.html))

**"Every time the CDC needs higher rates of new AIDS cases, it expands that definition once again, and more diseases are reclassified into the syndrome."**

# deBriefings

## CLASS ACTION LAWSUIT ON RITALIN FRAUD

The law firm of Waters & Kraus takes this opportunity to announce the filing in Texas of a class action lawsuit entitled "Hernandez, Plaintiff, Individually and on Behalf of all Others Similarly Situated v. Ciba Geigy Corporation, USA, Novartis Pharmaceuticals Corporation, Children and Adults with Attention-Deficit/Hyperactivity Disorder (CHADD), and the American Psychiatric Association. Dr Peter Breggin (author of *Toxic Psychiatry, The War Against Children* and *Talking Back to Prozac*) is serving as a medical consultant in the case.

While this filing is a departure from Waters & Kraus's continuing practice of toxic exposure and cancer cases, the pattern and practice of improper conduct on the part of the defendants in this case rivals that of the asbestos corporate defendants and tobacco companies in other cases.

The suit states allegations based on fraud and conspiracy. From approximately 1955 through 1995, the exclusive or primary manufacturer and supplier of Ritalin in this country was Ciba-Geigy Corp., USA ("Ciba") (Defendant). In 1996, Ciba merged with Sandoz Pharmaceuticals Corp. to become Novartis Pharmaceuticals Corp. ("Novartis") (Defendant). Ciba/Novartis has manufactured, marketed and sold Ritalin since approximately 1955.

Ciba/Novartis planned, conspired and colluded to create, develop and promote the diagnosis of Attention Deficit Disorder (ADD) and Attention Deficit Hyperactivity Disorder (ADHD) in a highly successful effort to increase the market for its product Ritalin. In addition to its actions and involvement with the creation of the ADD and ADHD diagnoses, Ciba/Novartis took steps to promote and dramatically increase the sales of Ritalin by way of the following:

1. Actively promoting and supporting the concept that a significant percentage of children suffer from a "disease" which required narcotic treatment/therapy;
2. Actively promoting Ritalin as the "drug of choice" to treat children diagnosed with ADD and ADHD;
3. Actively supporting groups such as Defendant CHADD, both financially and with other means, so that such organizations would promote and support (as a supposed neutral party) the ever-increasing implementation of ADD/ADHD diagnoses as well as directly increasing Ritalin sales;
4. Distributing misleading sales and promotional literature to parents, schools and other interested persons in a successful effort to further increase the number of diagnoses and the number of persons prescribed Ritalin.

Defendant CHADD (Children and Adults with Attention Deficit/Hyperactivity Disorder) has been a recipient of financial donations and contributions from Defendants Ciba/Novartis for many years. CHADD received US\$748,000 from Ciba/Novartis

in the period 1991 to 1994 alone. During the periods when CHADD received funding from Ciba/Novartis, CHADD deliberately made efforts to increase the sales of Ritalin, to increase the supply of methylphenidate (the generic name for Ritalin) available in the United States, and to reduce or eliminate laws and restrictions concerning the use of Ritalin and methylphenidate in the United States, all to the financial benefit of Ciba/Novartis. Ciba/Novartis made such financial contributions with the purpose of advertising and promoting sales of Ritalin, an internationally controlled substance. Ciba/Novartis has thus repeatedly violated Article 10 of the United Nations Convention on Psychotropic Substances, 1019 UNTS 175 (1971). CHADD's activities nation-

wide have led to a significant increase in the amount of Ritalin taken by schoolchildren and have directly resulted in enormous profits to Ciba/Novartis.

Parents, the school districts and other interested parties are generally unaware that use of Ritalin can cause a significant number of health problems and risks, including but not limited to the following:

- **Cardiovascular:** rapid heart beat (palpitations, tachycardia), high blood pressure (hypertension), unusual heart rhythm (arrhythmia), heart attack (cardiac arrest);
- **Central Nervous System:** altered mental status (psychosis), hallucinations, depression or excitement, convulsions/seizures (excessive brain stimulation), drowsiness or "dopey" feeling, confusion, lack of sleep (insomnia), agitation/irritation/anxiety/nervousness, hostility, unhappiness (dysphoria), impaired mental abilities (cognitive impairment on tests), jerky movements (dyskinesia, tics, Tourette's syndrome), nervous habits (such as picking at skin or pulling hair), compulsive behavior, depression/oversensitivity, decreased social interest, zombie-like behavior;
- **Gastrointestinal:** eating disorders (anorexia), nausea, vomiting, stomach ache/cramps, dry mouth, constipation,

**Ciba/Novartis planned, conspired and colluded to create, develop and promote the diagnosis of Attention Deficit Disorder (ADD) and Attention Deficit Hyperactivity Disorder (ADHD) in a highly successful effort to increase the market for its product Ritalin.**

abnormal liver function tests;

- **Endocrine/Metabolic:** growth problems (pituitary dysfunction), weight loss;
- **Other:** blurred vision, headache, dizziness, rash/conjunctivitis/hives, hair loss, inflammation of the skin (dermatitis), blood disorders (anorexia, leukoplacia), involuntary discharge of urine (enuresis), fever, joint pain, unusual sweating;
- **Withdrawal & Rebound:** sleep problems (insomnia), evening crash, overactivity and irritability, worsening of ADHD-like symptoms.

In addition, it is not generally known or understood by the public that use of Ritalin will preclude an individual from ever joining the US military, because Ritalin is classified as a Class II controlled substance along with other amphetamines and morphine.

Please send comments to [information@ritalinfraud.com](mailto:information@ritalinfraud.com).

(Source: Waters & Kraus website, [www.ritalinfraud.com](http://www.ritalinfraud.com))

---

---

# deBriefings

---

---

## BRAZIL'S MIRACLE MAN: A PERSONAL ACCOUNT

by Richard Hood © 2000

*Many of our readers have travelled to Brazil to receive healing through João de Deus at the House of Dom Inácio de Loyola, having read Robert Pellegrino-Estrich's article "The Amazing Cures of a Brazilian Miracle Man" in NEXUS 5/02 (Feb-March 1998) and/or his book The Miracle Man. In early August we heard that local reader Richard Hood had just visited the centre, so we asked him to report on his experiences.*

**D**ear Duncan: I have recently returned from South America after a trip to the healing centre of John of God (João de Deus) at Casa de Dom Inácio in Abadiânia in Goiás, Brazil. I would like to share my experiences with NEXUS readers so that they can read about the extraordinary healing events continuing to happen in the centre.

Two-and-a-half years ago, my brother David was struck down by a severe case of viral meningitic tuberculosis that ravaged his whole body and left him paralysed from the waist down. It produced two strokes in the brain and one in the spinal column, leaving him virtually a spastic. He was being fed via a feeding tube into the stomach and he's using a colostomy bag for his wastes to enable him to function normally.

His physical condition would be classified as virtually skin and bone. The doctors' opinion was that it was a miracle that he even survived the viral attacks. After the last two-and-a-half years in the conventional medical system, their opinion was that his present condition (as it was in June 2000 before we left) was as far as he would progress.

I read about the work of João de Deus in a NEXUS magazine article that appeared in 1998 [5/02] and was moved to read Robert Pellegrino-Estrich's book, *The Miracle Man*. Feeling there were no other viable options left for helping David, I put it to the family (which included my brother Michael) that we take him to João's centre in Brazil.

I contacted Robert and his wife Caterina in Sydney and asked about their trips to Brazil. We made bookings and then set off on 9 July on Robert and Caterina's tour, with the blessing of David's family. David's doctors gave us what amounted to a small suitcase full of drugs and supplies to support his medical needs.

From the moment Michael, David and I left New Zealand, where David lives, we felt we did not need to administer any of the drugs except for the pure codeine used to control the pain in David's legs. He suffered from considerable pain, and the pure, strong codeine was the only thing that brought relief when he went to sleep at night. Once we got to Casa de Dom Inácio, the healing centre, his dose of codeine went from 40 ml a night to 20 ml by the Full Moon of 16 July, and eventually down to nothing by the end of 20 days.

When we arrived, João started working on David within the first 24 hours and gave him an invisible psychic operation on the day. David began to show signs of improvement immediately. The most obvious change was that David started to sleep regularly and lengthily on the second night. He had not slept properly and peacefully for over two years. He began sleeping many long hours, both day and night, and the sleep was both undisturbed and

very deep. He began to eat like a horse (he had not eaten anything much solid for two-and-a-half years). His coughing and throat disturbances also diminished.

The doctors in New Zealand had said that David could not have bowel movements again and needed suppositories to assist him. He has now begun to have bowel movements every second day. João continued to see him three days a week, as is the normal pattern at the Casa, and he performed an invisible psychic operation every time he saw David.

Much to my surprise, on my second day there I had an invisible psychic operation on my kidneys and lungs. We began to find that we were all being worked on by João and his healing spirits ("entities", as they call them). João was prescribing us herbs to be taken three times per day, every day. I also had a physical operation over the heart on the third week I was there. That was amazing.

Because of the continuing improvements we've *all* had, we thought it best for David to stay in Abadiânia. He can now deliberately move his left leg. He's received sensations in both legs from his feet up. His attitude has now changed to smiles and lightheartedness. When his colostomy bag is now pinched off, he feels the pressure in his bladder. He's putting on weight and is getting his sense of humour back again.

While there, I saw many amazing healings. Every day I witnessed miracles, from tumours being removed, cancers healed, cataracts of the eye being whipped off and spirit possessions being removed. All that you hear is true!

When you travel to Brazil to Casa de Dom Inácio, it's important to understand that the healings you experience there are not all instantaneous. It's a personal journey for everyone. What I learned is that the pace of healing is very much to do with the person experiencing it.

David has been told he will walk again and be free of his tubes, and I look forward to sharing with your readers the rest of the journey. I returned from Brazil in early August, while Michael and David have stayed on to

keep receiving the grace, energy and healing at João's Casa.

I'd like you to note that 90 per cent of all the Westerners we spoke to while in Abadiânia were there because of the NEXUS article in 1998. They read all about João in the magazine or on the website.

I would recommend that if anyone wants to go to Abadiânia and gets the strong feeling to go, then check it out in your heart and if you feel okay, then go. You will not regret it and you will find yourself living a life of power and healing you never thought possible before going. All that we believe about the power of God and the individual healing him/herself is here right now.

Peace and best wishes,

Richard Hood

c/- Post Office, Mapleton Qld 4560, Australia

**Every day I witnessed miracles, from tumours being removed, cancers healed, cataracts of the eye being whipped off and spirit possessions being removed.**

**Contact Details:** For further information on the House of Dom Inácio healing centre and conducted tours, contact Robert and Caterina Pellegrino-Estrich on tel/fax +61 (0)2 9212 6345, e-mail them at [l1ight@ozemail.com.au](mailto:l1ight@ozemail.com.au), or visit their website, [www.johnofgod.com](http://www.johnofgod.com).







# ON HER MAJESTY'S SECRET SERVICE

*Britain's MI6 goes to extraordinary lengths to ensure the security of its intelligence operations, conducting them under the cover of official secrecy.*

*Part 1 of 2*

by Stephen Dorril © 2000

From chapter 36 of his book  
*MI6: Inside the Covert World of Her Majesty's Secret Intelligence Service*

Edited from the Cryptome website:  
<http://cryptome.org/mi6-sd36.htm>

Agent D/813317 Richard Tomlinson joined Britain's MI6 in 1991. Born in New Zealand, he read aeronautical engineering at Cambridge and was a Kennedy memorial scholar at the Massachusetts Institute of Technology, USA. Fluent in French, German and Spanish, Tomlinson was approached at university where he gained a first. A lecturer had asked him if he wanted to do "something stimulating" in the foreign service. Despite modern recruiting methods, the trusted old-boy network is still a favoured option at Oxbridge, and a number of other key universities, such as Durham and Exeter, still have a contact group of lecturers on the lookout for "firsts" as suitable recruits.

Historian Andrew Roberts has written about his own experience of being approached in 1987 to join the "FCO [Foreign and Commonwealth Office] Co-ordinating Staff", as MI6 is known: the "chat with a Cambridge contact", tea at the John Nash-designed Carlton House which overlooks St James's Park, "a discreet lunch a fortnight later and then a delightfully absurd mini-exam, in which one of the questions was, 'Put the following in order of social precedence: earl, duke, viscount, baron, marquis'". At Century House, Roberts recognised "several of the young Miss Moneypennys from the secretarial schools' parties at university". The questions continued in a farcical vein: "If I had been a communist, a fascist or a homosexual... Where do Britain's best long-term interests lie—Washington, Brussels or Moscow?" During the medical examination, he was told that "with Oxford, it's the drugs thing; with Cambridge, it's the boys". Attitudes have changed, and by 1997 MI6 was prepared to post a "gay couple"—"counsellor" and chief of station Christopher Hurran and his long-time Venezuelan lover—to the British Embassy in Czechoslovakia. A few years earlier, the Service had recruited a member of CND.

Finally, Roberts went through the process of positive vetting (known since 1990 as "EPV"). It is generally conducted by a semi-retired officer with a false name, who interviews referees and other contacts and undertakes checks on creditworthiness. Suitable candidates are put through the fast-stream Civil Service Selection Board. Roberts, however, decided not to join, and Tomlinson did so only after spending a number of years travelling and working in the City, during which time he had also signed up for the SAS territorial regiment. Over the last decade the Service has recruited a number of personnel from the special forces, though their gung-ho philosophy seems at odds with the image that MI6 has projected of the modern spy. Tomlinson eventually joined MI6 for old-fashioned "patriotic reasons" and sat the standard Foreign Office entry examination before being accepted onto the intelligence service training course.

New recruits are introduced to the traditional "tradecraft" of the world of spying and gain a broad range of knowledge from recruiting and running agents to developing agents of influence and organising and servicing "dead letter" drops. Because of the smaller numbers, MI6 officers indulge in less specialisation than their American counterparts, though the techniques are essentially little different from those used at the beginning of the century. The infamous Dreyfus affair began when a cleaning woman, Marie Bastian, working in the German Embassy but employed by the French Secret Service, handed over to her French controller the contents of the wastepaper baskets she emptied. MI6 recruiters still look out for "the life-and-soul-of-the-party types who could persuade the Turkish ambassador's secretary to go through her boss's wastepaper basket". These days, however, the spy is armed with a hand-held digital scanner which can hold the filched material in its memory and can also be used in emergencies to transmit the stolen secrets by burst transmissions via a satellite.

Such gadgets are developed for the Directorate of Special Support responsible for

providing technical assistance to operations—staffed by MoD [Ministry of Defence] locksmiths, video and audio technicians and scientists in sections devoted to chemicals and electronics, forensic services, electronic support measures, electronic surveillance and explosives systems. While the gadgets continue to provide the modern spy with a James Bond-like image—for instance, identification transmitters that can be hidden in an agent's shoes to enable the monitoring by satellite of their precise location—the reality is that most of the work is mundane and office-bound. Trainees still receive small-arms training at Fort Monkton, but much of the training is taken up with learning to use the computer system and writing reports in the house style.

## SECURITY PROCEDURES

As part of the Service's obsession with security, a great deal of time is spent on being indoctrinated in cipher and communications work.

Trainee officers are instructed on how to encrypt messages for transmission and how to use the manual B\*\*\* cipher, which is regarded as particularly secure. [See Editor's Note.] Used at stations abroad to transmit details of operations, potential sources and defectors, B\*\*\* is sent either via the diplomatic bag or by special SIS [Secret Intelligence

Service] courier. Diplomatic bags are not totally secure, as the success of the Service's own N-Section testified. It employed up to 30 people in Palmer Street, rifling the opened bags which were then expertly resealed. The work petered out in the mid-1960s as other means of communication took over.

Officers learn about "off-line" systems for the encryption of messages, such as N\*\*\*\*\*, used prior to transmission by cipher machines, and "on-line" systems for the protection of telegrams during transmission, code-named H\*\*\* and T\*\*\*\*\*. They are indoctrinated into the use of certain cryptonyms for forwarding telegrams to particular organisations and offices, such as SIS

headquarters which is designated A\*\*\*\*. They also learn about code-words with which sensitive messages are headlined, indicating to whom they may be shown. UK EYES ALPHA warns that the contents are not to be shown to any foreigners and are intended only for the home intelligence and security services, armed forces and Whitehall recipients. UK EYES B includes the above categories, the Northern Ireland Office, LIST X firms engaged in the manufacture of sensitive equipment, and certain US, Australian, New Zealand and Canadian intelligence personnel liaising with the Joint Intelligence Committee (JIC) in London. Additional code-words mark specific exclusions and inclusions. E\*\*\*\*\* material cannot be shown to the Americans, while

L\*\*\*\*\* deprives local intelligence officials and agencies of its content. Material for named individual officers, sometimes at specified times, is headed D\*\*\*\* or D\*\*\*\*, while particularly sensitive material about a fellow officer or operation is known as D\*\*\*\*\*.

The protection of files and their secure handling is a top priority, with officers taught to keep a classified record of their use and location. Photocopiers have the ability to mark and check the origin of non-authorized copies of classified material.

Following the development by MoD scientists of a means of reading a computer disc without a computer, all discs are protected in transit. All correspondence by letter is secured by specially developed red security tape which leaves detectable signs if tampered with, though near-undetectable photographic and laser techniques exist for reading the inside of mail and opening envelopes. Each officer has his own safe with dual-combination locking, while the filing cabinets with false tumbler locks as an added precaution are protected from penetration by X-rays. Since no lock is secure from picking, they collapse internally if anything more than the slightest force is used. In the event of drilling, a glass plate inside the door shatters, releasing a spring-loaded bolt to prevent opening. Frequent random checks take place on the number settings to see if the safe has been opened illegally.

These bureaucratic procedures and attention to minute security rules are not merely technical; failure to carry out security precautions can lead to points deduction in the security breach points system. If an officer racks up 160 points over three years (a breach of TOP SECRET counts as 80 points), this may lead to security clearance being withdrawn and instant dismissal.

New officers are initially based at the exotic Vauxhall Bridge headquarters, about which many Service personnel are sensitive, almost embarrassed. Access to "Ceausescu Towers", as some officers have dubbed it, is gained by use of a swipe card and PIN number. The

**Photocopiers have the ability to mark and check the origin of non-authorized copies of classified material.**

Following the development by MoD scientists of a means of reading a computer disc without a computer, all discs are protected in transit. All correspondence by letter is secured by specially developed red security tape which leaves detectable signs if tampered with, though near-undetectable photographic and laser techniques exist for reading the inside of mail and opening envelopes. Each officer has his own safe with dual-combination locking, while the filing cabinets with false tumbler locks as an added precaution are protected from penetration by X-rays. Since no lock is secure from picking, they collapse internally if anything more than the slightest force is used. In the event of drilling, a glass plate inside the door shatters, releasing a spring-loaded bolt to prevent opening. Frequent random checks take place on the number settings to see if the safe has been opened illegally.

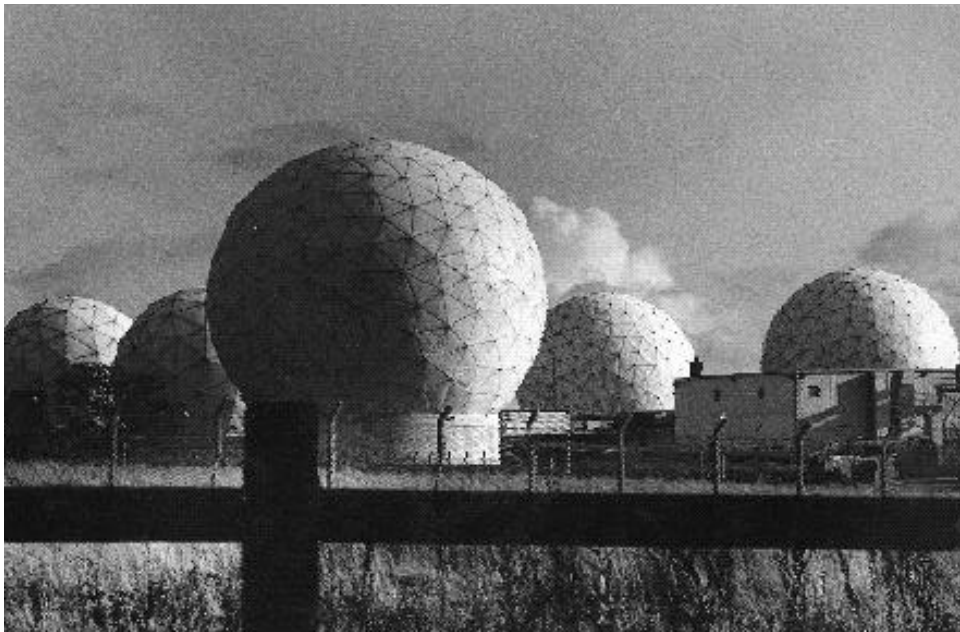

Menwith Hill "communications relay centre", Harrogate, UK

(Photo by Paula Solloway)

interior comprises a hive of bare, unmarked air-conditioned corridors. The only visible signs of occupancy are the acronyms on the doors, with nothing on the walls except floor plans and exit signs.

As with major stations abroad, such as Moscow and Beijing, Vauxhall Cross is classified as a Category A post, with a high potential physical threat from terrorism (HPT) and sophisticated hostile intelligence services (HIS). Operatives from the Technical Security Department (TSD) based at Hanslope Park, Milton Keynes, and from MI6's own technical department ensure that the building is protected from high-tech attack (HTA). There is triple glazing installed on all windows as a safeguard against laser and radiofrequency (RF) flooding techniques, and the mainframe computer, cipher and communications areas are housed in secure, modular, shielded rooms. A secure command-and-control room runs major operations—such as those in Bosnia, where "war criminals" were tracked and arrested by SAS personnel. Off the corridors are open-plan offices which give the impression of informality, though security overrides such considerations.

A new officer will find that more women than men are recruited to the Service (as has been the case since 1996), but men remain predominant particularly in senior positions. As in many modern offices, officers will be seen working at computers, processing information, collating files, planning operations, liaising with foreign intelligence agencies and networks and, most importantly, supporting the 300 to 500 officers in the field, though only half that number will be stationed abroad at any one time.

MI6 has been at the forefront of updating its information technology, and in 1995 installed at a cost of £200 million an ambitious desktop network, known as the Automatic Telegram Handling System (ATHS/OATS), which provides access to all reports and databases.

Staff are officially not allowed to discuss their work with colleagues, not even when they relax in the staff bar with its spectacular views over the River Thames, though, as Richard Tomlinson discovered, gossip is in fact rife.

## FOREIGN POSTINGS AND "INFORMATION OPERATIONS"

All officers will spend time in the field attached to embassies, though they will have little choice as to the location. Turning down a post will jeopardise future promotions and can lead to dismissal. Stations abroad are classed from the high-risk Category A, such as Yugoslavia and Algeria, to the lesser B, such as Washington and New York, C, the European countries, and D, often the Commonwealth, where there is little or no threat.

New officers might find themselves among the additional personnel sent to Malaysia, Thailand and South Korea, following the Service's boost to its presence in South-East Asia, or involved in operations into China, as followed the transfer of Hong Kong and the winding up of the Service's espionage operations in the former colony.

In a large station such as Washington, operating under "light" diplomatic cover will be a head of station (often a Counsellor), a deputy, and two or three officers (First and Second secretaries). There will also be back-up staff consisting of three or four secretaries, a registry clerk to handle files and documents, and communications and cipher officers. Easily identified by the trained eye in the Foreign and Commonwealth Office Diplomatic List—the number of Counsellor and First Secretary posts is limited and there tend to be too many for the positions available—an MI6 officer's presence will be known to the host intelligence and security agency. In some cases, a senior officer will make his presence known to draw attention away from his colleagues.

Before postings and missions abroad, officers receive a briefing from the Information Operations (I/Ops) unit which provides them with a list of sympathetic journalists who can be trusted to give them help and information. These contacts have become increasingly important in trouble-spots such as the Balkans.

I/Ops also has a more covert role in planning psychological operations along the lines of the old Special Political Action (SPA) section and the Information Research Department (IRD). I/Ops may also, according to a former MI6 officer, "attempt to influence events in another country or organisation in a direction favourable to Britain". One example is MI6's determined effort to "plant stories in the American press about Boutros-Ghali, whom they regarded as dangerously Francophile, in the run-up to the 1992 elections for UN Secretary-General".

Foreign operations of this sort do not require ministerial sanction.<sup>1</sup>

I/Ops also expends considerable energy behind the scenes in "surfacing" damaging stories designed to discredit critics of the Service. They will use off-the-record briefings of sympathetic journalists, the planting of rumours and disinformation which through "double-sourcing" are confirmed by a pro-active agent, and the overt recruitment of journalist agents. Journalists paid to provide information or to "keep their eyes open" are known as "assets" or "assistants" or just "on side".

According to Richard Tomlinson, paid agents included in the 1990s one and perhaps two national newspaper editors. An editor is unlikely to be directly recruited, as the Service would require the permission of the Foreign Secretary and would not like to be put in the position of being refused. Such high-fliers are more likely to have been recruited early in their careers. In this case, the journalist was apparently recruited at least three years before becoming an editor and remained an asset until at least 1998. Tomlinson has said that the editor was paid a retainer of £100,000, with access to the money via an offshore bank in an accessible tax haven. The editor was given a false passport to gain entry to the bank, which he regularly visited.<sup>2</sup>

In trying to identify the editor "agent", media interest centred on Dominic Lawson, son of the former Tory Chancellor of the Exchequer, who became editor of the *Spectator* in 1990 and had been editor of the *Sunday Telegraph* since 1995. Lawson denied that he had ever been "an agent, either paid or unpaid, of MI6 or

**Journalists paid to provide information or to "keep their eyes open" are known as "assets" or "assistants" or just "on side".**

**According to Richard Tomlinson, paid agents included in the 1990s one and perhaps two national newspaper editors.**

of any other government agency". On the other hand, the youngest brother of Lawson's second wife, Rosa Monckton, had joined MI6 in 1987. In 1996, Anthony Monckton was appointed First Secretary (Political) in the Croatian capital Zagreb.

Quite separately, the Princess of Wales—one of Rosa's closest friends and a godparent to the Lawsons' daughter—had clearly been under some kind of surveillance, as evidenced by the 1,050-page dossier held by the US National Security Agency (NSA) in its archive, detailing private telephone conversations between Diana and American friends intercepted at MI6's request. While all stories linking MI6 to the Princess's death in the car accident in France have been complete nonsense, it has been alleged that working closely with I/Ops in an attempt to deflect enquiries away from the security services had been a chief of staff to "C", Richard Spearman, temporarily posted to the Paris embassy with his assistant, Nicholas Langman.<sup>3</sup>

Operational officers can be casually spotted by the \*\*\*\*\* roller-ball pens in their top pocket (it was discovered by accident that they have the ability to create invisible ink), the Psion organiser and the specially adapted Walkman they carry to record conversations for up to ten minutes on the middle band of an ordinary commercial music cassette tape. They also use laptop computers for writing reports. If that seems like a recipe for disaster, the secret hard disc contains a protected back-up.

The station is usually sited in a part of the embassy regularly swept by technical staff for bugs and other electronic attack. It is entered using special door codes with an inner strongroom-type door for greater security. Following all the procedures learned during training, officers handling material up to the SECRET level work on secure overseas Unix terminals (S\*\*\*\*) and use a messaging system known as ARRAMIS. Conversations by secure telephone masked by white noise are undertaken via a special SIS version of the BRAHMS system. A special chip developed by GCHQ [Government Communications Headquarters] apparently makes it impossible even for the US NSA to decipher such conversations. Secure Speech System (H\*\*\*\*\*) handset units are used by SIS officers within a telephone speech enclosure. The most important room is electronically shielded and lined with up to a foot of lead for secure cipher and communications transmissions. From the comms room, an officer can send and receive secure faxes up to SECRET level via the C\*\*\*\*\* fax system and S\*\*\*\*\* encrypted communications with the Ministry of Defence, Cabinet Office, MI5 (code-name SNUFFBOX), GCHQ and 22 SAS. An encrypted electronic messaging system working through fibre optics, known as the UK Intelligence Messaging Network, was installed in early 1997 and enables MI6 to flash intelligence scoops to special terminals in the MoD, the Foreign Office and the Department of Trade and Industry. Manned twenty-four hours a day, 365 days a year, and secured behind a heavy thick door, the cipher machines have secure "integral protection" known as TEMPEST. MI6 officers abroad also work alongside GCHQ personnel, monitoring foreign missions and organisations.

**Officers abroad may also be asked to aid more sophisticated operations designed to build up the Service's psychological profiles of political leaders.**

**A special department within MI6 has tried in the past to procure the urine and excrement of foreign leaders.**

Officers in the field may include not only those officially classed as diplomats, but also others operating under "deep" cover. Increasingly, MI6 officers abroad act as "illegals". It is known that Service officers are sometimes employed during the day in conventional jobs such as accountancy and provided with false identities. British banks—the Royal Bank of Scotland is particularly helpful, and to a lesser extent the Midland—help supply credit cards to officers working under cover. At the end of each month, officers have to pay off their aliases' credit cards. Banks also help transmit money overseas for covert operations. During the Cold War, banks in the Channel Islands and other off-shore locations acted as a conduit for secret funding.<sup>4</sup>

Recruiting or running agents and gathering intelligence are the prime objectives of these deep-cover operatives, and their real work, some claim, starts at six in the evening when the conventional diplomats begin their round of cocktail parties. Such social events can be very useful for gathering intelligence and spreading disinformation. Baroness Park recalled that one of MI6's more successful ploys was "to set people very discreetly against one another". "They destroy each other. You don't destroy them." Officers would offer the odd hint that it was "a pity that so-and-so is so indiscreet"; not much more. Officers will also deal with paid "support agents"—those who supply MI6 with facilities including safe houses and bank accounts as well as intelligence. There are also "long insiders"—agents of influence with access to MI6 assessments and sanitised intelligence. The Service's deep-cover agents have burst transmitters with the ability to transmit a flash signal to MI6 via a satellite when they are in danger.<sup>5</sup>

Officers abroad may also be asked to aid more sophisticated operations designed to build up the Service's psychological profiles of political leaders. A special department within MI6 has tried in the past to procure the urine and excrement of foreign leaders. A specially modified condom was used to catch the urine of

Romanian leader Nicolae Ceausescu, while the "product" of Cuban President Fidel Castro and Russian President Leonid Brezhnev was "analysed" by medical specialists for signs of their true health.

#### **TOMLINSON'S UNDER-COVER MISSIONS**

Tomlinson's duties included recruiting agents to inform on foreign politicians. His most important task was to infiltrate in 1992 a Middle Eastern weapons procurement programme network—the BMP3—with the object of locating and disabling a chemical weapons facility. Authorised by an unnamed senior Cabinet minister, the sabotage plan—one account suggests the planting of a bomb—aimed to intercept a shipment of machinery and interfere with its extractor fan equipment, despite warnings of the possible risk to the lives of dozens of civilian workers at the plant.

In November 1992, using the name "Andrew Huntley" and the pretext of assisting at a conference run by the *Financial Times*, Tomlinson went under cover to Moscow. His very sensitive

mission was to obtain Russian military secrets on ballistic missiles and effect the defection of a Russian colonel who specialised in this area. Although, strangely, he was not given the usual "immersion" language training in Serbo-Croat, Tomlinson soon found himself in the former Yugoslavia, whose break-up had taken the Service by surprise.<sup>6</sup>

When the country fractured in January 1991 into Croatia, Bosnia and Serbia, EU [European Union] recognition of independent Croatia proved to be a critical and disastrous policy, eventually paving the way for Serb aggression which the Foreign Office interpreted as civil war. MI6 had been running a few federal sources in the old Yugoslavia, but they provided little worthwhile intelligence.

The Service lacked appropriate linguists and had to start more or less from scratch. The JIC established a Current Intelligence Group (CIG) on the Balkans, and within 18 months MI6's Controllerate dealing with the area had recruited a number of sources at a high level from among the ethnic military and political protagonists.

During 1993, as a "targeting officer" within the Balkans Controllerate whose job was to identify potential informants, Tomlinson spent a harrowing and dangerous six months travelling as a journalist to Belgrade, Skopje, Zagreb and Ljubljana, in the process recruiting a Serb journalist (journalists of every nationality were a particular MI6 target in the Balkans, as they proved to be more productive than most other sources) and a leader of the Albanian opposition in Macedonia. In 1993, UN blue-helmeted troops started patrolling the borders of the former Yugoslav Republic of Macedonia. According to sources, MI6 used air-drops in an operation to set up arms dumps on the border of Macedonia as part of a "Stay Behind" network.<sup>7</sup>

Another operation included running as an agent a Tory MP, who gave information about foreign donations to the Conservative Party. Parliamentary Private Secretary to the Northern Ireland Minister, Harold Elleston was an old Etonian who studied Russian at Exeter University and subsequently became a trade consultant specialising in the former Eastern Bloc countries, during which time he was recruited by MI6. He worked for them in Eastern Europe, the former Soviet Union and during the conflict in former Yugoslavia.

After visiting former Yugoslavia in 1992, Elleston, who was employed by a lobbying firm with Conservative candidate John Kennedy (aka Gvozdenovic), notified his MI6 handlers that donations were reaching the Conservative Party from Serbia. Despite Harold Wilson's ruling in the 1960s that the intelligence services would not use MPs as agents, the Service received special sanction from Prime Minister John Major to continue Elleston's secret role. Sir Colin McColl warned Major that the party was possibly accepting tainted money via Kennedy, a key figure in arranging payments from the Serb regime.<sup>8</sup>

## MI6 & THE FOREIGN OFFICE'S BALKANS AGENDA

MI6 was itself seen as being pro-Serb in its reporting. In 1994, two articles arguing against Western policy in the Balkans conflict appeared in the *Spectator* (the right-wing magazine unknowingly served as "cover" for three MI6 officers working in Bosnia, Belgrade and Moldova), written under a Sarajevo dateline by a "Kenneth Roberts", who had apparently worked for more than a year with the United Nations in Bosnia as an "adviser". Written by MI6 officer Keith Robert Craig, who was attached to the MoD's Balkan Secretariat, the first article, published on 5 February, rehearsed arguments for a UN withdrawal from the

area, pointing out that all sides committed atrocities. The second, on 5 March, complained baselessly about "warped" and inaccurate reports—by the BBC's Kate Adie, in particular—of an atrocity against the Bosnian Serbs.

*Guardian* correspondent Ed Vulliamy recalled being invited to a briefing by MI6 which was "peddling an ill-disguised agenda: the Foreign Office's determination that there be no intervention against Serbia's genocidal pogrom". The carnage that took place in Sarajevo's marketplace was described, without

the slightest evidence, as the work of the Muslim-led government which was alleged to be "massacring its own people to win sympathy and ultimately help from outside". As Vulliamy knew, Sarajevo's defenders were "dumb with disbelief". Despite UN Protection Force reports which found that it was Serb mortars which were killing Muslims, the MI6 scheme "worked—beautifully", as the allegations found their way into the world's press. Vulliamy noted that "it was quickly relished by the only man who stood to gain from this: the Serbian leader Radovan Karadzic".<sup>9</sup>

Perhaps it was only an Intelligence/Foreign Office faction which was pro-Serb. From March 1992 until September 1993, Tomlinson worked in the East European Controllerate under the staff designation UKA/7. He has claimed that in the summer of 1992 he discovered an internal document that detailed plans to assassinate President Slobodan Milosevic. During a conversation,

**Another operation included running as an agent a Tory MP, who gave information about foreign donations to the Conservative Party.**



Richard Tomlinson

an ambitious and serious colleague, Nick Fishwick, who was responsible for developing and targeting operations in the Balkans (P4/Ops), had pulled out a file and handed it to Tomlinson to read. "It was approximately two pages long, and had a yellow card attached to it which signified that it was an accountable document rather than a draft proposal." It was entitled "The need to assassinate President Milosevic of Serbia", and was distributed to senior MI6 officers including: the head of Balkan operations (P4), Maurice Kenwick-Piercy; the Controller of Eastern European operations (C/CEE), Richard Fletcher, and later, Andrew Fulton; the security officer responsible for Eastern European operations (SBO1/T), John Ridd; the private secretary to the Chief (H/SECT), Alan Petty ("Alan Judd"); and the Service's SAS liaison officer (MODA/SO), Major Glynne Evans. According to Tomlinson, Fishwick justified assassinating Milosevic on the grounds that there was evidence that "the Butcher of Belgrade" was supplying weapons to Karadzic, who was wanted for war crimes including genocide. US and French intelligence agencies were alleged to be already contemplating assassinating Karadzic.

There were three possible scenarios put forward by MI6. Firstly, to train a Serbian paramilitary opposition group to carry out the assassination. This, Fishwick argued, had the advantage of deniability but the disadvantage that control of the operation would be low and the chances of success unpredictable. Secondly, to use the small INCREMENT cell of SAS/SBS personnel, which is especially selected and trained to carry out operations exclusively for MI6/MI5, to send in a team that would assassinate the President with a bomb or by a sniper ambush. Fishwick said that this would be the most reliable option, but would be undeniable if the operation went wrong. Thirdly, to kill Milosevic in a road crash which would be staged during one of his visits to the international conferences on former Yugoslavia in Geneva. Fishwick suggested that a stun device could be used to dazzle the driver of Milosevic's car as it passed through one of Geneva's motorway tunnels.<sup>10</sup>

A year later, Tomlinson acted as a Counsellor to the Commander of the British forces in Bosnia and worked at manipulating sources in the Karadzic entourage. One participant to these operations suggests that these sources "produced a very detailed intelligence picture which included not just the military plans and capabilities of the different factions, but also early warning of political intentions". There appears to have been little evidence of this intelligence coup in the Foreign Office decisions that followed, and its value is contradicted by another source which, while admitting that several significant agents were recruited, concludes that they did not "produce substantial intelligence of quality".<sup>11</sup>

The intelligence deficit was worsened by the US unwillingness to provide its Atlantic partner with all its intelligence on the

Serbs. General Sir Michael Rose, a former head of the SAS and Commander-in-Chief of the UN Protection Force, realised that during 1994 all his communications were being electronically intercepted and his headquarters in Sarajevo "bugged" by the Americans, because Washington—which wanted to use NATO air strikes to bomb the Serbs to the negotiating table—thought the British were too supportive of the Bosnian Serbs. The Americans also monitored the communications of SAS scouts deep in Bosnian territory and discovered that they were deliberately failing to identify Serb artillery positions. This lack of trust caused friction and led to a backstage confrontation between the secret services. It reminded some observers that the special relationship existed only on the basis that the US saw Britain as a chance to extend its reach into Europe.<sup>12</sup>

Continued next issue...

**General Sir Michael Rose,  
a former head of the SAS  
and Commander-in-Chief  
of the UN Protection Force,  
realised that  
during 1994 all his  
communications were being  
electronically intercepted  
and his headquarters in  
Sarajevo "bugged" by  
the Americans...**

#### Endnotes

1. *Punch*, no. 71, 2 January 1999.
2. *Sunday Business*, 20 December 1998, 24 January 1999. Family friend and former Conservative defence procurement minister, Jonathan Allen, who was an MI6 agent, providing insights into the Saudi royal family and their defence spending plans.
3. *Sunday Business*, *ibid*.
4. *Sunday Business*, 11 October 1998.
5. *Observer*, 21 November 1993; *Panorama*, BBC1, 22 December 1993.
6. *Sunday Times*, 22 September 1996, 21 December 1997, 2 August 1998.
7. *ibid*.
8. *Observer*, 22 December 1996.
9. *Guardian*, 25 March 1998, 7 October 1998; *Sunday Times*, 30 August 1998; *Independent*, 2 September 1998.
10. *ibid*.
11. Urban, Mark, *UK Eyes Alpha: The Inside Story of British Intelligence*, pp. 215-16; *Sunday Times*, 22 September 1996, 21 December 1997, 2 August 1998.
12. *Guardian*, 20 December 1994; *Times*, 10 November 1998.

#### About the Author:

Stephen Dorril is a writer/researcher in the field of security and intelligence services. He has written articles for major UK newspapers, magazines and journals, and has appeared on numerous radio and television programs. Stephen is also a co-founder of the respected British journal *Lobster*.

#### Editor's Note:

- Stephen Dorril's article is edited from chapter 36 (pages 783-800) of his book, *MI6: Inside the Covert World of Her Majesty's Secret Intelligence Service* (published by The Free Press, New York, 2000). NEXUS downloaded the extract from the Cryptome website, <http://cryptome.org/mi6-sd36.htm>.
- Cryptome advises that code-word, cipher and communications systems disguised by the author on legal advice are shown as printed (e.g., "B\*\*\*"). It invites information for publication on the true form of these code-words as well as information about the systems; e-mail [jya@pipeline.com](mailto:jya@pipeline.com).







# DECLOAKING PATHOGENS WITH LOW-FREQUENCY SOUND

*A variety of disease-causing pathogens and health problems can be identified in the voice print and can be cancelled out by the input of complementary frequencies and harmonics.*

by Sharry Edwards, MEd © 2000

SOUND HEALTH  
PO Box 416

Albany, Ohio 45710, USA

Telephone: +1 (740) 698 9119

Fax: +1 (740) 698 6116

E-mail: sound@frognet.net

Website: www.soundhealthinc.com

Throughout history, mankind has been plagued by infectious diseases. With the advent of modern biochemical antibiotics, many of these older diseases seem to have been eradicated. However, many new diseases have been identified, some of which are mutations of previously "cured" diseases, in the form of resistant pathogens. Our entire ecosystem has now become vulnerable to these resistant pathogens due to the fact that as these invaders move from host to host they mutate, so that what worked against them today doesn't work tomorrow. This has caused extreme concern for those in charge of public health. If we don't have the resources to keep up with the mutations, how can the public be protected? How will the people even know how to take precautions against infection?

Controversial biophysicist Hulda Clark, PhD, ND, stated in her book, *The Cure For All Disease*, that cancer, one of the most feared of diseases, is caused by pathogens—specifically, parasites whose life cycles are aided and abetted by modern chemicals that we encounter. She is certainly not alone in identifying links between parasites/pathogens and modern illness. Chronic fatigue shows a strong connection with Epstein Barr virus. Heart disease and pulmonary embolism have been connected with *Chlamydia pneumoniae*. The list is long and growing. To add to the problem, these pathogens have been able to use the body's processes against it. Using the sloughed-off protein of the host, these pathogens have the ability to create a protective cloak so that the body will be fooled into thinking that the pathogen is part of our normal form and function.

## SOUND SOLUTIONS FOR OVERCOMING DISEASE

What can be done to combat this problem? The Sound Health Research Institute, a non-profit organisation located in rural Ohio, USA, has been conducting studies using an emerging technique known as BioAcoustics™ to help find answers. [See Sharry Edwards's article in NEXUS 4/03, April–May 1997, for background information. Ed.]

In recent months, BioAcoustics technology has been shown under microscopic observation to be able to dissolve the ringed protein barrier used by some of these pathogens to cloak themselves. The technique was used successfully against the Epstein Barr virus, *Chlamydia pneumoniae* bacterium and yeast. It has potential in the eradication of such diseases as chronic fatigue, influenza, AIDS, etc., and it certainly will help in the fight against antibiotic-resistant pathogens including the resistant "flesh-eating bugs" which have been in the news recently.

At the beginning of the study, frequencies identified in Dr Clark's book were used, but it was found that these were not accurate or that mutations in the pathogens had taken place, thus making these frequencies unusable and necessitating the search for new, correct frequencies. Below is a short review of the initial study, involving 17 participants, in which the Epstein Barr virus, the *Chlamydia pneumoniae* bacterium and yeast were targeted. (Note that in the case of the yeast, the decloaking and deactivation happened so quickly that the yeast could not be seen within a minute or so.)

## Epstein Barr Virus

A filmed recording of the activity under the microscope shows that when the coating of the Epstein Barr virus was dissolved, the neutrophils (the white blood cells that attack invaders) were activated. The activity of the neutrophils was nil until the Epstein Barr was decloaked by the appropriate frequency, even though the two were separated by minute distances. As the decloaking transpired, it was obvious that the neutrophil had not

been aware of the invader until the protein coating had begun to dissolve. After the decloaking, the neutrophil continued to consume the invading pathogen.

Here are some additional notes from the study:

- This is listed by Dr Clark as having the musical note of C#, but we found it to range from mid C# to early D.
- When the pathogen numbers were high, there was an active invasion as well as symptoms (the most common being fatigue) which varied in intensity.
- When the antigen frequencies were high, antibodies were being produced.
- When detoxing the Epstein Barr virus, ear and throat infections, pain and sensitivity in those areas were noticed. Reports show that Epstein Barr virus tends to hide in the neck area.

### **Chlamydia pneumoniae**

Bio-acoustic voice spectral analysis has been shown to be an inexpensive (the lab testing for *Chlamydia pneumoniae* costs US\$400 per test) and quick way to determine which pathogens are present and which antibodies have been manufactured by the body. In the case of *Chlamydia pneumoniae*, researchers were able to identify those participants in the study who had been infected by the bacterium, those who had created antibodies to it, and those who were on their way to being free of the infection.

Additional notes from the study are as follows:

- This bacterium was not listed by Dr Clark.
- This is not the sexually transmitted variety of Chlamydia; the *Chlamydia pneumoniae* strain is airborne and it attacks the lungs and pulmonary system. Its symptoms include laboured breathing, dizziness and passing out, accelerated heart rate, high blood pressure and muddled thinking. Reinfection is possible after symptoms have disappeared. The bacterium has an incubation period of 10–14 days.
- The frequency of *Chlamydia pneumoniae* corresponds with the musical note of C#, and also involves the note of A, which is associated with blood clotting.
- For active cases, a narrow band of C# was active in each chart, and late A to early A# was also involved.
- For those with high protease levels, symptoms did not appear.
- For those with blood type O, symptoms were short and less severe.
- When the Frequency Equivalent™ of Epstein Barr virus was high, an active infection was present.
- When the antigen frequencies were high, antibodies were being produced.
- The *Chlamydia pneumoniae* formed clots which formed a protective coating that cloaked the entire clot from the neutrophils. These clots are not shown in chest X-rays or clotting factor scans. It is suggested that a pulmonary arteriography or a spiral CT of the lung be ordered to verify the presence of these small clots in the lung tissue.
- Eating fatty foods or heavy meals exacerbated symptoms of laboured breathing. Depending on how much fatty food or how large the meal had been consumed by the participant, symptoms would dissipate within half an hour to four hours after treatment. Participants who had poor digestion of protein were most vulnerable. Trauma (brand name) from Thera-zyme has a particularly high dose of protease and was used along with digestive enzymes to ease or dissipate the symptoms.

**Rife and many others knew that frequency is the key to controlling pathogens. It is the key to stimulating the body to fight its own pathogens.**

• Doxycycl HYC, a potent antibiotic, is reported to be able to kill this strain of *Chlamydia pneumoniae*, but had little effect in this case. Giving the frequency equivalent for Doxycycl produced side effects as if the medication had been given, even though the subject had never taken it before.

- One infected and particularly vulnerable client exhibited small, thin, pinch-like bruises.
- One client had a pacemaker implanted by doctors, to stop an accelerated heart rate, but the breathing problems and muddled thinking were still present after the placement of the pacemaker.
- One client was told that he needed heart surgery to clear blocked arteries, but, obtaining a second opinion, he discovered that this was not necessary.
- One client was told by the medical establishment that absolutely nothing was wrong, except simply stress.
- Four persons in the study ended up in the hospital, but not one hospital discovered that a pathogen was causing the problem.

### **Chlamydia pneumoniae Linked to Heart Disease**

An article published in the June 2000 issue of the *Townsend Letters for Doctors and Patients* stated that the high and rising incidence of heart disease in many cases can be attributed to undiagnosed *Chlamydia pneumoniae* which continuously re-infect the human host.

Jeffrey S. Bland, PhD, with Sara H. Benum, MA, in a recent publication, *Genetic Nutritioneering* (Keats Publishing, Los Angeles, 1999), reported the following (pp. 142-144):

"Swedish medical researchers spent several years trying to determine the cause of death of 16 very fit athletes; all of whom died of sudden cardiac arrest while performing. Post mortem examination revealed evidence of inflammation of the heart, which

seemed to be caused by a chronic infection with the parasite *Chlamydia pneumoniae*.

Following up on this discovery, investigators in the cardiology division at the University of Utah School of Medicine confirmed the strong correlation between heart disease and infection with *Chlamydia pneumoniae*.

Improving protein (including milk protein) digestion is a major step in eliminating the availability of sloughed-off protein that is used for cloaking by such pathogens as *Chlamydia pneumoniae*.

### **FREQUENCY, THE KEY TO FIGHTING PATHOGENS**

Using frequency to decloak these pathogens is the first step in establishing control.

"We feel we are adding to the information that Rife started and the Universe was not ready to receive," said Karen Almashy, a participant in the Sound Health Research Institute study. "In Rife's time, it wasn't so urgent; now it is."

Rife and many others knew that frequency is the key to controlling pathogens. It is the key to stimulating the body to fight its own pathogens. The main issue has been finding the correct frequency, in light of the constant mutations, and the appropriate wave form. Giving the body direct square waves can cause damage. The new techniques must provide frequencies in exacting patterns, using short bursts, for approximately eight minutes. Using frequency in this way provides a very powerful and effective avenue to dissolve the ringed protein barriers.

Why does frequency work to dissolve ringed protein barriers

used by resistant pathogens to cloak themselves? And what is frequency? Light is frequency. Sound is frequency. Aroma is frequency. Emotion is frequency. Vibration is frequency. Music is frequency. Brain waves are frequency. Nerve impulses are frequency. Everything, at its most common denominator, is frequency. Frequency is everything and everything is frequency. In reality, there are no solids. We exist in a universe that consists entirely of energy. Einstein proved this. Frequency defines it.

How does the body know what to do with all of these frequencies? The body hears frequency. The ears change that sensory input into biochemical impulses and send that information to the brain. The eyes feast on frequencies of light input, change those impulses into biochemical energy and send that information to the brain. The nose receives aromas. Each impulse is changed into biochemical input and sent to the brain. Each sensory organ collects information as frequency input and changes that input into biochemical impulses which it sends to the brain. The brain in turn digitises the information and redistributes it to systems and functions of the body so that the body can maintain homeostasis.

How does the brain know how to route these inputs to the appropriate part of the brain? Answer: by the octave of frequency. If the frequency comes in at a level of:

- 1–2 cycles per second, the brain interprets this as biomagnetic input;
- 2–4 cycles per second, the brain interprets this as bioelectrical input;
- 1–4 cycles per second, the brain interprets this as genetic frequency input (biomagnetic and bioelectric input combined);
- 4–8 cycles per second, the brain interprets this as biochemical input;
- 8–16 cycles per second, the brain interprets this as structural (muscular/skeletal) input;
- 16–32 cycles per second, the brain interprets this as neurophysical input.

Each frequency, or frequency set, has specific functions, both structural and functional, within the body. Each frequency set does its own work and can share frequencies from its set for other biological systems to use. This has been known to occur but, until very recently, the mechanism by which it occurred was not defined.

The body, in its infinite wisdom, has a perfect feedback loop to make it possible for the body to diagnose and provide a set of healing frequencies as a self-diagnosis and prescription. The system—the voice to provide sound, and the ear to perceive sound—is a perfect diagnostic tool that can provide reliable predictive, preventive and curative options for self-healing. In no other system in the body is a feedback loop used in such a conscious way. This system is operating even when we are comatose. It only ceases when our life-force ceases—and we really don't know that for sure. Our ears transmit a stabilising sound, an oto-acoustic emission, which is a constant attempt to provide healing frequencies to the body.

This ability is just now being considered as a viable complement to modern medicine, but references from ancient civilisations reveal that sound had been used for thousands of years to balance and maintain health. Tibetans know the positive vibrational effects of bells and chanting. Traditional Chinese medicine

practitioners recognise that properly flowing energy, or *chi*, is fundamental to good, balanced health. The Bible equates "the Word", a form of sound, with God and creation.

Today it seems that these ancient wisdoms are being revisited as conventional medicine, with its previous reliance upon the scientific method, begins to pay attention to the potential of frequency to nourish and support the body's capacity to self-heal. The medical establishment is just starting to recognise the relationship between the frequencies of the voice and nutritional status (see Danielle Campbell's article in *Advance Journal for Speech Language Pathologists and Audiologists*, 31 May 1999).

Each one of us possesses unique harmonies of frequency that can be expressed through the voice. However, when the frequencies of the body become unbalanced, that disorder is also expressed through the voice and manifests as disease or stress at the structural and biochemical levels of the body.

A short section of the voice—a recording of less than a minute in duration—can be assessed using a system that analyses an individual's frequency status. Those frequencies, in specific combinations, can then in turn be used to support normal form and function.

#### HARMONICS, CHORDS AND FREQUENCY EQUIVALENTS

Each note and frequency has a series of other frequencies that it "plays" with to create holistic balance within a system of the body.

Each note and frequency also has a series of harmonics that it "plays" with to create the harmonics we observe throughout the systems of the body.

Harmonics can be used to nourish multiple systems that are in stress. For instance, the frequencies that can be used to normalise and cause "spontaneous remissions" in some types of cancer (a limited subject base) are the harmonics of the Krebs cycle (the citric acid cycle, a series of steps in the oxidation of carbohydrates). In studies, these frequencies were presented using specific patterns to

achieve and maintain an harmonic "chord" that is a specific, recognisable mathematical matrix.

Normally these mathematical matrix frequency sets can be used for treating one system or one issue. However, many systems within the body use these chords. Interestingly, these have been emulated and written down in musical theory, without our necessarily realising that these chords already exist within our cells as musical mass and frequency.

Each nutrient, biochemical substance, organ and emotion has a series of predictable relationships that are mathematical in nature. For example, the frequency equivalent of choline (a necessary nutrient of the B-vitamin family) has an opposite or balancing frequency equivalent. These two frequencies work together to harmonise the body and the energy conversion system. If you subtract the numeric frequency equivalent of choline from the 6th harmonic (180 degrees out of phase) frequency equivalent of choline, the result is the frequency equivalent of acetylcholine. This is exactly the process that the body goes through when these compounds are introduced. In other words, what the body does with compounds can be predicted and shown mathematically.

**A short section of the voice—a recording of less than a minute in duration—can be assessed using a system that analyses an individual's frequency status.**

## THE MATHEMATICAL MATRIX OF THE BODY

The body is a mathematical matrix of frequency interactions. Biochemical relationships are frequency relationships.

Consider the following. The suggestion that the number 8 is the opposite of the number 11 is a foreign notion to most people. No such model is taught in school, but the reality is that our body knows this concept to be true and responds to numbers and frequencies in its attempt to conduct the normal processes of the body.

Actually, mathematical opposites are easily understood when one considers other forms of opposites recognised by both science and the arts. Each colour has an opposite, known as a pigment or light complement. Each colour can be represented by a frequency. The frequency sets which represent complementary colours can also be considered frequency complements. BioAcoustics refers to these frequency complements as Frequency Equivalents.

Just as green and red are opposite or complementary colours, there are green frequencies (in the frequency range of 11) and red frequencies (in the frequency range of 8). Using this concept, an overabundance of the frequency of 11 can be equalised by using the frequency of 8, and vice-versa. By using 8 (or any frequency we choose as a base), we can begin to construct formulas that the body uses innately to provide balance to the body.

Using data from vocal analysis, it can be shown that every muscle, every compound, every process and structure of the body has a frequency equivalent that can be mathematically calculated. The body's ability to heal itself originates as an interaction, biochemical and/or structural, which is a predictable mathematical frequency response.

For example, calcium and magnesium are used together in the body. When you combine the frequency equivalents of calcium and magnesium, the frequency equivalent of phosphorus is the result. Phosphorus is a compound that is required for calcium and magnesium to be synergistic. Frequency harmonics of the body matrix imitate the body's reactions which science has already discovered. Human biological reactions and the frequency equivalents of the mathematical matrix are the same.

One of the frequencies that has been shown to be able to strengthen the thumb is the note of C. By presenting the specific note within the range of C that is required, it can be shown that the thumb muscles become stronger. Giving the frequency complement of the same muscle will cause the muscle to weaken. Since the frequency equivalent of the thumb muscle happens to correspond to the frequency equivalent of zinc, the body will also accept the compound of zinc as a support for that muscle.

Our physical bodies are apparently built on, and correspond to, a blueprint created by thousands of these combinations. Each organ, muscle, nutrient or biochemical has a frequency equivalent and Harmonic Matrix™ that are interrelated via the central processing unit, the nervous system and the brain.

A vocal print can show the combination of notes and the corresponding frequencies that can be used to create the coherent mathematical patterns that are required by our bodies. When these patterns become dissonant, dis-ease is the result. How simple, then, to monitor and maintain our own health through a daily review of our vocal print?

Some frequencies are apparently more important to our states of health than others. The frequency of 16 is a very important inter-

nal frequency, since it can help release oxygen and calcium into the cells. In his book *Cross Currents* (Jeremy P. Tarcher, Inc., Los Angeles, 1990), Robert Becker, MD, substantiated that calcium, an invaluable nutrient in the body's healing processes, is released by the frequency of 16 cycles per second.

The most compelling information concerning the number 16 as a frequency harmonic may change medicine and the way we treat disease. This is an expansion the concept of harmonics postulated by Pythagoras, the 6th century BC mathematician. He observed that if one of two strings, which have the same length and the same degree of tension, is then divided in half, the half string, when vibrated, creates an harmonic exactly one octave higher than the original full string. As Pythagoras continued to divide the string, he observed the harmonic principles that still govern much of the musical theory in use today.

The discovery of the mathematical relationships underlying the science of sound clearly demonstrates that harmonics was not an abstract concept but adheres to strict and predictable mathematical principles. These precise harmonics, used in combination with the frequency equivalents, form an intricate harmonic synergy that maintains the sonostatis essential for optimal health.

Our body functions as a compilation of frequencies and frequency relationships. The brain functions through the use of brain waves which are measurable as frequency. The heart emits frequency to keep the heart beating in rhythm. Nerve transmission is accomplished through the use of frequency pathways. Organs, nerves, tissue and bone are themselves made up of substances which are, at their base, energy—measurable in cycles per second. The body is alive with frequencies that interact in cooperative resonance, in harmony.

All of the frequency equivalents that correspond to the use of nutrients and biochemicals that relate to a particular harmonic set can be used to evaluate the efficacy of the interactions involved. This mathematical matrix maps the crossroads of alchemy and cooperation between the different systems of the body. If a mineral, fatty acid, amino acid, biochemical and enzyme, for example, have similar frequencies, they may all participate as nearly interchangeable components performing the same work. Sulphur and palmitic acid are similar frequency equivalents. They can substitute for each other in the fight against invading pathogens. Other compounds that are found within the same harmonic set react in analogous fashion.

The body is adept at compensating, substituting and transmuted frequencies. If an enzyme isn't available to help counter invading pathogens, fatty acids and minerals can be substituted.

Frequency-equivalent harmonic sets can be used to establish substitutes using mathematical matrix relationships. This means that if we construct an harmonic set for the frequency equivalents of vitamin C, we can use this listing to observe every other compound that interacts with vitamin C and, in addition, see the structural aspects most affected by vitamin C.

In the clinic, a frequency can be presented to a subject and the voice monitored to observe the frequency equivalents of compounds that are influenced. In a great many instances, many of the interactions were previously unknown. For example, in a study that was conducted to determine the originating factors of knee problem in tennis players, it was found that the knee was not the actual root cause; the base problem turned out to be in a foot muscle.

**Our body functions as  
a compilation of  
frequencies and frequency  
relationships.**

BioAcoustics research indicates that standardised, harmonic sets can be used to predict, depict and monitor the chemical and behavioural interactions and relationships of living systems.

When all of the frequency equivalents of compounds and physiology are known, every aspect of any one frequency can be studied. We will be able to understand frequency relationships and how they relate to all other structures, processes and biochemicals. In the not-too-distant future, then, we will be able to develop an elemental frequency grid similar to the periodic table of elements. Every compound has a frequency equivalent based on its molecular weight. Presenting a frequency equivalent in analog form to the body, allows the body to detect the presence of that compound. When an additional frequency, based on a mathematical formula of the frequency equivalent, is presented, the substance becomes functional.

A frequency equivalent that allows this awareness by the brain is called a Brain Wave Multiple (BWM). In disease, the body may not have the necessary BWMs to identify or stimulate a compound or muscle. A frequency equivalent can provide the BWMs that act to stimulate the detection and function of a compound or structure. From the data presented so far, it seems that the heart provides the actual rhythm of the frequency (the wave form), while the brain provides the actual frequency to be used.

Note that it is imperative that BWMs be presented in an *analog* (not digital) form. According to Robert O. Becker and many other researchers, the body's input mechanisms are analog and respond most efficiently to analog input.)

#### WHAT THE VOICE CAN REALLY TELL YOU

The frequencies of the voice can be predictive, diagnostic, prescriptive and curative. The vocal print can identify toxins, pathogens, supplements that are too high or low in level, and muscles that are weak or strong. Systems that do not cooperate can be detected through a vocal assessment, as can the root cause of a disease or symptom. The vocal print can match the most compatible medication for a person and can identify medications that are not doing well. It can even match compatibility for dating and job placement!

#### Voice frequencies can be predictive

Michael was on his way to the secluded Sound Health Research Institute in rural Ohio to demonstrate a new product. He was

intrigued by this new BioAcoustics technique he had heard so much about, and wondered if it could really reveal the physical condition of the body.

Michael was given a tour of the facility and quickly accepted the offer to have his voice analysed. His vocal print revealed that he might have a serious thyroid issue, but Michael had no medical history or evidence of any such problem. Just to be sure, it was suggested that Michael visit his medical practitioner. The lab results taken a few days later indicated nothing abnormal. Both Michael and his medical practitioner were pleased that nothing was wrong, had a good laugh about the shortcoming of this new technique and went back to life as usual.

Nine days later, Michael collapsed with a set of mysterious symptoms that stumped the local doctors. His heartbeat was erratic, he was sweating profusely, he was anxious and disoriented. The doctors were puzzled, but Michael remembered the vocal test. As it turned out, a serious thyroid condition was indeed the problem. The vocal print had revealed, nine days *prior* to any physical symptoms or lab results, that his thyroid was in stress.

#### Voice frequencies can identify biochemical toxins

Over the summer, seven-year-old Andi, a top reader last session, had forgotten how to read. Her teacher demanded that Andi be put in a special reading class. This embarrassed Andi and made her reluctant to go to school. She cried every day. On the days she didn't cry, she pretended to be sick.

Andi was brought to a BioAcoustics clinic, where vocal testing was used to determine if there were any biochemical reasons for her reading problems. During that session, while she was receiving low-frequency sound, Andi was able to read clearly and without hesitation. The test pointed to the possibility that Andi had been poisoned by formaldehyde, a chemical preservative.

A detoxification program was initiated, and Andi's teacher noticed immediate and striking differences in the girl. Andi's self-esteem soared. She was again a bright, cheerful, intelligent child. Best of all, she could read again!

#### Voice frequencies can ascertain muscle stress, trauma and weakness

Bob was an attorney, but more than that he was a motorcycle enthusiast. Five years ago, Bob had an accident so severe that the doctors wanted to amputate his leg. Being an avid tennis player,

Octave and Frequency Correlates for Body Function and Structure

Primary Colour	Note	Mid-C	C-1	C-2	C-3	C-4 Beta	C-5 Alpha	C-6 Theta	C-7 Delta	C-8 X
Red	C	261.60	130.80	65.40	32.70	16.35	8.18	4.09	2.04	1.02
Red/Orange	C#	277.20	138.60	69.30	34.65	17.33	8.66	4.33	2.17	1.08
Orange	D	293.70	146.85	73.43	36.71	18.36	9.18	4.59	2.29	1.15
Orange/Yellow	D#/Eb	311.10	155.55	77.78	38.89	19.44	9.72	4.86	2.43	1.22
Yellow	E	329.60	164.80	82.40	41.20	20.60	10.30	5.15	2.58	1.29
Yellow/Green	F	349.20	174.60	87.30	43.65	21.83	10.91	5.46	2.73	1.36
Green	F#	370.00	185.00	92.50	46.25	23.12	11.56	5.78	2.89	1.45
Green/Blue	G	392.00	196.00	98.00	49.00	24.50	12.25	6.12	3.06	1.53
Blue	G#/Ab	415.30	207.65	103.82	51.91	25.96	12.98	6.49	3.24	1.62
Blue/Violet	A	440.00	220.00	110.00	55.00	27.50	13.75	6.88	3.44	1.72
Violet	A#Bb	466.20	233.10	116.55	58.28	29.14	14.57	7.28	3.64	1.82
Violet/Red	B	493.30	246.65	123.32	61.66	30.83	15.42	7.71	3.85	1.93
					<b>n-phy</b>	<b>str/mus</b>	<b>emot</b>	<b>ch/nut</b>	<b>b-elec</b>	<b>b-mag</b>

**Key:** n-phy = neurophysical; str/mus = structural muscular; emot = emotional; ch/nut = chemical nutritional; b-mag = biomagnetic; b-elect = bioelectric

Bob refused to allow the operations, but after four years of physical therapy there was little hope that he would ever be able to walk normally again. The lower portion of his leg was as large as a football; he could not walk straight nor bend his ankle, and his stamina for any exercise was gone. Bob closed his law practice and went home to his parents who lived in a small community in Ohio. He felt that his life, as he wanted it to be, was over.

In a local grocery store, Bob met a local tennis player who later introduced Bob to an experimental technique being offered at a local college. Two months later, after working with BioAcoustics, Bob was back on the tennis court giving the locals a challenging workout. He could walk straight; he could almost run; he could chase a tennis ball. The swelling dissipated and his leg now had muscle tone and movement. He had his life back again and he was ecstatic. Bob was doing so well on the court that he was asked to be the tennis coach at the local high school.

### Voice frequencies can identify pathogens

Voice frequencies can identify pathogens and also provide mathematical frequency sets that can assist the body eradicate them, as in the following example.

Laura was very tired. Her medical tests provided little help. A darkfield blood examination confirmed that Laura had Epstein Barr virus. The frequencies of Epstein Barr show as an invading pathogen in the vocal print. A mathematical set of formulas was developed and used to decloak the pathogen and assist the body to identify the intruder. Once the pathogen was pointed out, the killer cells of the body easily identified and attacked the pathogen. This worked well with the bacteria and yeast in Laura's body. She has now resumed her active lifestyle.

### Voice frequencies can be diagnostic

Barbara had Paget's disease. Her bones were in a constant state of destruction and replacement that resulted in overdeveloped, light, porous bones. Barbara had broken her hip and had just got out of the hospital when she sought an answer through BioAcoustics vocal analysis. Paget's is regarded as incurable, so her physician was not hopeful. However, Barbara was convinced that a cure was possible and she was determined to explore every avenue of alternative practice.

Barbara's first session revealed that a little-known supplement was not being utilised by her body. The supplement was identified as a mineral that is stressed when Paget's disease is present. The supplement was quickly added to her daily intake of vitamins. Barbara is off crutches and recently called to report that she has been out square-dancing!

### Voice frequencies can self-prescribe

A female jogger was referred to the clinic because one leg was two inches shorter than the other due to the trauma of a hit-and-run incident. An operation was scheduled to try to elongate the bone.

The voice print was able to show that a thigh muscle was very tight. Low-frequency analog sound was presented to relax the muscle. Within a few minutes of muscle manipulation, both legs

were the same length, and, with exercise, have continued to remain in the normalised state.

## HARMONIOUS HEALTH

These examples represent only a small fraction of the information that can be gleaned from vocal prints. The field of vocal analysis, utilising the idea that frequencies contained in the voice are holographic representations of one's state of health, is quickly gaining a reputation for excellence.

Research has repeatedly shown that every muscle, compound, process and structure of the body has a frequency equivalent that can be mathematically calculated. This provides the foundation for the concept that the body's ability to heal itself can originate as frequency interactions between the molecular signals of the entire body. When these patterns become discordant, dis-ease is the result. When presented the correct low-frequency analog sound, a new harmony can result, with the person experiencing notable self-healing.

In addition to viewing the body as a mathematical matrix,

**The field of vocal analysis, utilising the idea that frequencies contained in the voice are holographic representations of one's state of health, is quickly gaining a reputation for excellence.**

BioAcoustics considers the idea that frequencies can be used to predict states of disease and stress before they become obvious on a physical level. Protocols are being developed to identify the frequency relationships for cancer, heart disease, arthritis and sports injuries, regeneration and anti-ageing. The study of numerous vocal prints permits researchers to recognise obvious frequency-markers for various states of illness.

Using the voice to monitor the body is a new, developing science. Not all of the answers are obvious, but there is enough known information for definitive patterns of disease states to be established. Dr Andy Weil, Dr Robert O. Becker, Dr William Tillis, Dr Josh Oschman, Dr Alfred Tomatis and Dr Richard Gerber, among other distinguished professionals, all agree that frequency and rhythm, as various forms of energy, can be important aspects of understanding and healing the body.

Voice analysis, with its capabilities for predictive, pre-diagnostic and evaluative assessments of the body, is well on its way to becoming an intrinsic part of regular health care.

Just as a rainbow is incomplete without its full spectrum of colours, the body needs full-spectrum sounds that are created by the corresponding harmonic sets to establish and maintain the perfect state of health.

### About the Author:

Sharry Edwards, MEd, is Executive Director of Sound Health Research Institute, Inc., a non-profit, educational research institute dedicated to the emerging field of BioAcoustics. Courses developed from the technology, pioneered by Edwards, are the genesis of a three-level Allied Health Program offered by Hocking College, Ohio—the only accredited sound-healing certificate course in the USA. Edwards, an international speaker and author, regularly lectures on BioAcoustics and conducts workshops for professionals.

### Editor's Note:

Further information on BioAcoustics and contact details for leading practitioners in various parts of the world can be obtained from the Sound Health website, [www.soundhealthinc.com](http://www.soundhealthinc.com).







# SHAKEN BABY SYNDROME OR ADVERSE VACCINE REACTION?

*Many parents have been charged with murder for allegedly shaking their babies to death, but medical evidence suggests that vaccinations are to blame in a large number of these cases.*

by Maureen Hickman © 2000

PO Box 274  
Ettalong Beach, NSW 2257  
Australia  
Telephone: +61 (0)2 4342 5294  
Fax: +61 (0)2 4342 5379  
E-mail: acii@ozemail.com.au

To loving, caring parents, the act of child abuse is abhorrent. However, it must be recognised that child abuse has occurred in the past and inevitably will occur in the future. Medical professionals have the unenviable task of establishing, by applying sound medical practice and scientific evidence, if child abuse has in fact occurred.

Shaken Baby Syndrome (SBS) was described in medical literature in the early 1970s<sup>1</sup> but was recognised as a form of severe child abuse as far back as 1860.<sup>2</sup> It is a collective term for internal head injuries which a baby or young child may sustain from:

- (a) being violently shaken (child abuse);
- (b) a combination of medical problems exacerbated by a serious vaccine adverse event;
- (c) a lone serious vaccine adverse event.

According to *New Scientist*,<sup>3</sup> researchers may be on the way to identifying a biochemical signature that can help distinguish between brain injuries caused by accidents and those resulting from violent abuse. Whilst this research may identify SBS, it may not identify underlying medical problems which have been exacerbated by a serious vaccine adverse event or a lone serious vaccine adverse event. Unless sound scientific evidence is initiated swiftly to diagnose the difference, parents could find themselves in the position of a father in Sydney, Australia, who in 1995 was charged with the murder of his child.

## THE TRAGIC DEATH OF RIKKI LEE WALTERS

Scott Warren Walters was charged with the murder of his four-month-old baby daughter, Rikki Lee Walters, by allegedly shaking the baby to death on 22 April 1995. Rikki Lee was born on 23 January 1995 at 41 weeks' gestation. The apgar scores (the scale, from 1 to 10, upon which a baby's physical health is judged) were 8 at one minute and improved to 9 at five minutes. She was vaccinated on 19 April 1995, 72 hours prior to her death. Vaccines given were triple antigen (diphtheria, tetanus, pertussis), Hibtiter (*Haemophilus influenzae*), hepatitis B and polio syrup.

The transcript of an electronically recorded interview between the police and Scott Warren Walters is significant:

**Q:** Did she have any medical problems which you were aware of any time in between those two visits to the doctors?

**A:** Oh, we were worried about her chest, 'cause she was, um, breathing a bit heavy and like, we took, the doctor said she's just got a cold.

**Q:** When did the doctor say that?

**A:** When we took her to, um, get her needles and that, she was...

**Q:** So, you were worried about her chest when you took her to the doctors.

**A:** Yeah, we were; her chest was, since she was born, like she had a...she caught a cold, and, you know, through the month...through, like, the second month, she's caught a cold and it hasn't gone away; it was just...her breathing was just heavy.

The transcript of the police interview with the mother is also significant:

**Q:** Did Rikki Lee receive any vaccination?

**A:** Yeah; the other day it was her two-month-old needles, 'cause she had a cold when they were due; ones for polio, hepatitis B, measles and mumps, all that type of thing.

**Q:** Did Rikki Lee have diarrhoea?

**A:** No.

**Q:** Did she have vomiting?

**A:** She's always been a vomity baby after she is fed, but no more than usual.

**Q:** Did she have cold symptoms?

**A:** She's had a snuffly chest and nose, she had a *really bad reaction to the needles*. She only had them on Wednesday; she had a runny nose since this.

[Author's emphasis in italics.]

The fact that Rikki Lee had a bad reaction to vaccination was also noted by the police in the "Report of Death to the Coroner", dated 23 April 1995:

"The deceased received two-monthly injections on Wednesday 19.4.95 on her three-monthly period because she had been sick. The deceased then suffered a bad reaction to the injections; however, the mother did not return her to the doctor. [Signed by constable.]"

It is noted that the medical practitioner said the following in a statement to police:

"I cannot recall this consultation; however, it [is] my usual practice to *observe* the child and ask general questions as to the child's health. If the child had been obviously unwell with fever, the vaccination would not have been ordered. Further, the child did not appear to have any physical injuries or [to be] suffering from neglect; and if the child had been, I am aware of the guidelines in relation to [my] contacting the Department of Community Services. The child received the vaccinations from nursing staff, as this is usually the normal practice at the centre." [Author's emphasis in italics.]

We know that the child was ill because both parents alluded to this fact when giving police statements. Did the medical practitioner give adequate information to the parents on the risks and benefits of vaccination so an informed decision could be made? The father alleged that the medical practitioner, in a consultation lasting three to four minutes, did not take any notes of the consultation, did not examine the child for contraindications to the administration of a vaccine, did not question the parents on the health of the child, and did not explain the risks and benefits of vaccination.

If the medical practitioner did not recall the consultation, how could he remember whether there were any physical injuries or whether the child was suffering from neglect? *Remember, the doctor took no notes* according to the parents. The doctor made the statement: "If the child had been obviously unwell with fever, the vaccination would not have been ordered." We know, however, that the doctor admitted only to *observing* the child, so how could he make a diagnosis of whether the child had any contraindications for the administration of the six vaccines?

The *Australian Immunisation Procedures Handbook*<sup>4</sup> is distributed by the National Health and Medical Research Council to give medical practitioners guidance about vaccination and to encourage them to maintain the highest standards in the provision of vaccination services. The 5th edition of this handbook, distributed in October 1994, is very clear on the issue of consent and advises practitioners that informed consent must be obtained from

the person being vaccinated or, in the case of a child, the child's parent or guardian. The handbook advises that consent should be obtained prior to each vaccination, after the recipient's fitness and suitability have been established, and that the person being vaccinated or the parent/guardian should be informed of all possible side effects.

It does appear that the medical practitioner in this instance was clearly negligent because he did not follow government guidelines in the provision of vaccination services. He did not establish Rikki Lee's fitness for vaccination correctly, as she was subsequently found to have been suffering from viral pneumonia. Seventy-two hours later, disastrous results emerged from his carelessness.

Following this vaccination, Rikki Lee slept for 10–11 hours on Friday night, 21 April 1995, the night before her death. Was this "excessive somnolence"? This is defined by Peter O. Behan, Professor of Neurology at Southern General Hospital, Glasgow,

as "a state of drowsiness" and is an adverse reaction to vaccination.<sup>6</sup> He wrote: "Albeit, this may be difficult to quantitate but, normally, mothers will be aware that the child will be difficult to arouse, will not take its food, and most mothers will note that the child is sleeping excessively."

According to the transcript from an additional police interview, Scott Warren Walters was asked about feeding details on the day Rikki Lee died:

**A:** ...she only, she didn't have it; she wouldn't have been two minutes; she was on the bottle and she just...

**Q:** About two minutes on the bottle?

**A:** Yeah.

**Q:** And what, she wasn't interested in the food?

**A:** No, no.

The father admitted that Rikki Lee, following the administration of the vaccines, had shown signs of excessive drowsiness, projectile vomiting and diarrhoea, had not been taking the full amount of her formula and was on continual doses of Panadol every six hours.

#### DOCTORS CALLED BY CROWN LEGAL TEAM

In the case of *Regina v Scott Warren Walters*,<sup>5</sup> heard by Acting Judge Black in the NSW Supreme Court in April 1998, the Crown called three expert witnesses: a forensic pathologist, a paediatrician and a neuropathology professor.

##### • The forensic pathologist reported:

"There were no fractures of the skull; subdural haemorrhage was present diffusely across the superior surface of the right cerebral hemisphere. There was no evidence of bruising of the neck. There were no fractures of the rib cage. No digested food was seen in the intestine and there was minimal faecal material within the colon. An X-ray skeletal survey was performed, and no evidence of old or recent trauma or other bony disease was seen."

##### Acting Judge Black commented on the forensic pathologist's testimony in his Judgment:

"Examination of the fixed eyes noted haemorrhages around both sides of the optic nerve and diffuse retinal haemorrhages...

The father admitted that Rikki Lee, following the administration of the vaccines, had shown signs of excessive drowsiness, projectile vomiting and diarrhoea, had not been taking the full amount of her formula and was on continual doses of Panadol every six hours.

There was laryngopharyngitis and moderate microvesicular steatosis present in the liver... Cytomegalovirus was isolated from a nasal swab. She said that cytomegalovirus was a viral pneumonia which she would not expect to cause death but would expect to cause something like a bad cold, maybe bronchitis... She was not able to say how long Ricki Lee had been suffering from viral pneumonia.

"The microscopic examination of the subdural haemorrhage told her that the haemorrhage occurred within around 12 hours prior to Ricki Lee's death."

The forensic pathologist determined that the direct cause of death was subdural haemorrhage occurring up to approximately 12 hours prior to death. No antecedent causes or other significant conditions that may have contributed to the death were listed.

In cross-examination, the following questions and answers were put and given:

**Q:** And first of all, it is the case, is it not, that there is some controversy within the medical profession about this whole issue of shaken baby syndrome?

**A:** Yes.

**Q:** There are those who would debunk the whole idea completely?

**A:** There are certain people that say that shaking alone is insufficient to cause injuries, that there must be impact as well; and there are others that say that the shaking is sufficient.

**• The paediatrician, Chairman of the Child at Risk Committee at Westmead Hospital, Sydney, reported:**

"The clinical and pathological findings are almost certainly the result of a violent shaking injury to the child in the short time prior to her death."

Slightly later in his report, he said this:

"The only other possible explanation for a spontaneous haemorrhage into the brain would be some form of haemorrhagic disease such as vitamin K deficiency in the neonatal period. I understand that she did receive her vitamin K injection and this would virtually rule out this possibility."

**In his Judgment, Acting Judge Black commented on the paediatrician's findings:**

"In the course of his evidence, the paediatrician had said that he felt strongly about his position and I asked him to clarify what he meant by that. He said it was not because he was trying to make out that he was zealous about the matter; it was just that because of the range of injuries within the brain, he felt it was consistent with violent shaking, way out ahead of any other possibility; in terms of percentages, something like 99 per cent, something like that.

"He was not aware that the child had been vaccinated about three days before her death.

"He says that the presence of cytomegalovirus would not be a contraindication for immunising the child. He said the current advice is that immunisation should be done unless there is a particularly serious illness.

"In relation to the microvesicular steatosis found by the forensic

pathologist, he [paediatrician] did not refer to it in his report. He said in relation to it:

"It is not something I think I could comment on, but I think I was concentrating largely on the injuries that were documented but it is obviously important in the context."

**Q:** When you say you cannot comment on it, are you saying you cannot comment on microvesicular steatosis?

**A:** Yes, I would have to be told what that is. I don't know what that is."

"I am surprised [said Judge Black], in view of those answers, that the paediatrician felt able to be as positive in his conclusions as he was."

**• A neuropathology professor also gave evidence for the Crown. Commenting on his testimony, Acting Judge Black wrote in his Judgment:**

"Injuries are consistent with the child having been shaken. He was asked, 'Would it be possible for a child to have received these injuries and to appear normal to a number of adults over a period of hours?' A: 'Yes.' When asked to put a time frame on this, he said, 'The injuries could have happened twenty-four to forty-eight hours prior to the arrival of the ambulance on the Saturday night'. He was unaware that the child had been vaccinated three days prior to the death. He noted the presence of cytomegalovirus but that did not cause him any concern, nor did he see any relationship between that and the vaccination.

"He did not consider whether scurvy was a problem and said, 'Scurvy is a diagnosis that...again I am no [more] expert on the clinical aspects of vitamin deficiencies than I am on the vitamin aspects of brain problems, but scurvy does not normally cause any brain pathology'."

It was clear from the medical evidence tendered that *the subdural haemorrhage was the cause of death* and was probably less than 24 hours old. The retinal haemorrhage would have occurred near the time of death and could have been caused by resuscitation. In other words, there were

two instances of haemorrhage allegedly caused by the baby being shaken.

**DOCTORS CALLED BY DEFENCE LEGAL TEAM**

Two medical practitioners were called on behalf of the defence in the case of *Regina v Scott Warren Walters*.

**• Dr Mark Donohoe, MB, BS, gave the following testimony:<sup>7</sup>**

"The contributing and unusual factors in this case do make it difficult to attribute the intracranial bleeding to a single cause. The range of contributing and potentially causative factors include: hepatic mitochondrial abnormality (as evidenced by the microvesicular steatosis of the liver); antibiotic use in the neonatal period; cytomegalovirus (CMV) infection causing pneumonia; poor feeding and fluid intake causing a depletion in glutathione; multiple antigen vaccination administered while she was suffering a significant viral infection; adverse reaction to the vaccination;

**"He was unaware that the child had been vaccinated three days prior to the death. He noted the presence of cytomegalovirus but that did not cause him any concern, nor did he see any relationship between that and the vaccination."**

the use of paracetamol to manage her high temperature; nutritional deficiencies, including vitamins K and C."

**This is an extract from Acting Judge Black's Judgment concerning Dr Donohoe's testimony:**

"In summary, his [Dr Donohoe's] report focuses on the moderate microvesicular steatosis present in the liver, found by the forensic pathologist. He says this condition arises from an inherited or acquired disorder of hepatic mitochondrial function. This was either inherited by Rikki Lee from her mother or caused by a toxic drug reaction. This type of hepatic damage would be expected to cause coagulation and bleeding disorders. In his view, the administration of an antibiotic when Rikki Lee was eleven days old, the presence of the cytomegalovirus infection, the administration of the vaccines, the administration of Panadol and possible vitamin deficiencies all combined to the possible sudden onset of spontaneous bruising and bleeding in a previously apparently healthy child.

"He disagreed with the forensic pathologist's evidence that the steatosis of the liver was consistent with viral infection from the cytomegalovirus. He said the literature and research in the last five years had been fairly definitive that microvesicular steatosis is a mitochondrial disorder.

"I [Judge Black] have considered the forensic pathologist's evidence about this carefully, and on this issue I am not satisfied that Dr Donohoe is wrong."

• **Dr Archie Kalokerinos, MB, BS, well-known (retired) general practitioner and author of the book *Every Second Child*,<sup>8</sup> also gave evidence for the defence. This is an extract from his testimony:**

"A possible cause of Rikki Lee's death was scurvy haemorrhage precipitated by pertussis vaccine.

"The precipitating factor giving rise to scurvy is the endotoxin contained in pertussis vaccine, and the amount of endotoxin varies tremendously from one batch to another. In addition, endotoxin is more likely to be stimulated in production because bottle-fed babies do not have normal bowel flora. Also, the administration of antibiotics can stimulate the production of excessive amounts of endotoxin. Vitamin C neutralises the effects of endotoxin; however, infants exposed to endotoxin can develop a sensitivity which can precipitate extremely acute and even fatal symptoms occurring without warning.

"The presence of a viral infection means more utilisation of vitamin C and probably causes the production of endotoxin in the gut. All the factors necessary for the production of scurvy haemorrhages are present in this case."

**Regarding Dr Kalokerinos and his evidence, the Acting Judge noted:**

"He said from his own experience and from the research he had done, haemorrhages can occur in scurvy. The haemorrhages noted by the forensic pathologist could all have been caused by scurvy. The vitamin deficiencies and problems arising therefrom are far more common amongst Aboriginal and part-Aboriginal children than amongst Caucasian people. (It is noted here that the

accused's evidence was that he was Aboriginal.) He says, in the present case, the vitamin C deficiency was a very likely possibility, 'much more likely than any other possibility'. He disagreed with the professor's evidence that scurvy did not normally cause any brain pathology.

"It will be remembered that the professor had disclaimed any expertise in vitamin deficiency. Further, the professor had not said that scurvy could not cause any brain pathology; the words he used were 'does not normally cause'. Accordingly, I am not satisfied beyond reasonable doubt that scurvy cannot cause brain pathology."

**Acting Judge Black, in the Supreme Court of New South Wales, Criminal Division, in handing down Judgment on 24 April 1998, said:**

"In relation to those two doctors [i.e., doctors for the defence], I had the opportunity of seeing them both give their evidence and be carefully and comprehensively cross-examined in the witness

box. I have also paid attention to the written submissions provided to me by the respective counsel. I did not form the view that either of those doctors was putting forward a fanciful, untenable proposition. Perhaps, putting the burden the correct way, I am not satisfied that their evidence should be rejected as unreliable, nor am I satisfied that their propositions are unreasonable.

"...Suffice it then to say, in this case, having regard to all the evidence before me including, in particular, that given by witnesses whom I have seen, my verdict is that the accused is *not guilty*." [Author's emphasis in italics.]

An innocent man would have been jailed in this matter if the Judge had not found that the medical practitioners for the defence were presenting reasonable propositions for alternative medical reasons, including a vaccine adverse event, rather than SBS for the death of the baby. Other accused parents have not been so fortunate.

**COMPARISON WITH SBS/VACCINE CASES IN UK & USA**

In the United States, a father has been jailed for life after a jury found him guilty of causing SBS. Baby A.<sup>9</sup> was born in September 1997 and vaccinated eight weeks later with diphtheria, tetanus, pertussis (DTP), hepatitis B, polio syrup and Hib (*Haemophilus influenzae*)—exactly the same vaccines that were administered to baby Rikki Lee.

It is interesting to note that Baby A. had advanced bilateral pneumonia, whilst Rikki Lee was diagnosed as having viral pneumonia. Both mothers noted that their babies had chest congestion from birth to death and had a falling-off of feeding patterns and increased lethargy following the administration of vaccines.

Clearly, the medical condition of both babies following birth should have precluded them from undergoing any vaccination, and especially not six vaccines at the one time. It is obvious that the babies in the two cases mentioned had underlying medical problems that were exacerbated by the administration of multiple vaccines and that a vaccine adverse event contributed to each death.

The post-mortem findings on Rikki Lee found subdural

**An innocent man would have been jailed in this matter if the Judge had not found that the medical practitioners for the defence were presenting reasonable propositions for alternative medical reasons, including a vaccine adverse event, rather than SBS for the death of the baby.**

haemorrhage of the right cerebral hemisphere and retinal haemorrhages were noted. In the case of Baby A., the findings found subdural haemorrhages of the right and left cerebral hemispheres as well as retinal bleeding. It is also interesting to note that both mothers had urinary tract infections during pregnancy and were treated with antibiotics.

The father of Baby A. is fighting for his life and is presently seeking sufficient worldwide medical expertise to file an appeal. Many medical professionals around the world have responded to his request for support, including Dr Archie Kalokerinos who gave evidence in the Walters trial.

Another tragic case in the United States is that of a mother who has been jailed for life for allegedly shaking her quadruplets. The naturally conceived quadruplets were born two months prematurely, weighing around three pounds each. When the babies were three weeks old, they were given hepatitis B vaccine—following which, all four babies became ill and required hospitalisation. Two babies ultimately required insertion of shunts in their brains to release blood and fluid as a result of subdural haemorrhages.

Immediately the babies were hospitalised, the medical professionals made a diagnosis of SBS. These four babies are now scheduled for adoption and the maternal grandmother has been dismissed by state authorities as a possible candidate.

In the United Kingdom, a 35-year-old lawyer was recently convicted of the double murder of her baby sons. Christopher died in 1996 and Harry in 1998. Sally Clark was accused of shaking Harry to death. Because of that accusation, it was alleged that it was too much of a coincidence to believe that Christopher did not die in 1996 in exactly the same way, even though death at the time was attributed to "natural causes". Harry was diagnosed with retinal haemorrhage; however, one medical expert prior to the trial had doubts about this diagnosis, as he claimed he had been looking at the wrong slides. This disclosure weakened other medical experts' evidence of SBS, but it was not sufficient to sway the jury from a verdict of guilty. Christopher was vaccinated 23 days before his death, and Harry on the day he died; so it is feasible that both of these babies could have died from a severe vaccine adverse event.<sup>10</sup>

There was a divergence of medical opinion at the trial of Sally Clark as well as at the trial of the father of Baby A. The question must be asked whether juries are capable of understanding complex, conflicting medical evidence empowering them to judge a person's guilt or innocence in such cases. It is interesting to note that in the Australian case of Walters, a Judge alone found the defendant not guilty.

### ACCURATE CASE ASSESSMENT

It should be noted that SBS may not always result in the death of a baby. In New South Wales recently, parents of a child suffering a serious vaccine adverse event were suspected of SBS. The baby has been removed from the care of the parents and placed with a Department of Community Services (DOCS) foster parent. The law in New South Wales<sup>11</sup> gives representatives of DOCS the

right to attend on the residential address of any parent suspected of abusing children. A notice<sup>12</sup> is served on them to present their child forthwith to a nominated medical practitioner at a hospital or some other place so specified so a medical examination of the child can take place.

Under the law, the Director-General of the Department of Community Services may keep the child for "such period of time as is reasonably necessary for the child to be examined". A court of law will ultimately decide the fate of the baby, i.e., whether the baby would be returned to the care of the parents or whether it would be fostered out to family or other carers. Following a hearing, it is possible that the court could refer the matter to the police. The situation may then arise where a person is charged with a criminal offence (SBS), even though the injuries to the baby may well have been reported to the appropriate authorities by that person as a serious vaccine adverse event.

It is clear that the diagnosis of SBS requires meticulous medical investigation. This investigation will be made much more difficult in the future with the recent endorsement by governments around the world of hepatitis B vaccination of all newborns. As more vaccines are released onto the market, the number of serious vaccine adverse events—including death—will increase in our children and at a younger age.

The problem is the failure of medical professionals to recognise that vaccine adverse events do occur and that they are guilty of labelling them "coincidental" or "by chance".<sup>13</sup>

In Australia, six deaths<sup>14</sup> have been reported from vaccines in the 27-month period from 6 June 1997 to 2 September 1999. Because of the under-reporting and under-recognition of such events, it is likely that death and other serious injuries occur in much higher numbers than the public has been led to believe. In other words, it is more politically correct to label the death or injury of a baby as SBS than to investigate the safety and effectiveness of vaccines which are considered by governments and the majority of the medical profession as the only panacea for the

treatment of infectious diseases.

Clinical trials prior to licensure of vaccines are notoriously small, and this inhibits researchers' ability to establish accurately the cause and effect relationship between vaccines and serious adverse events. Vaccine trials are usually funded by vaccine manufacturers themselves and are unlikely to quantify accurately the true "risks vs benefits" ratio, lest it reflect on sales and marketing strategies.

What is seriously lacking is independent scientific research with large numbers of trial participants, where one half is given the vaccine and the other half is given a placebo.

Dr Mark Donohoe, the Sydney medical practitioner who gave evidence for the defence in the Walters trial, was very explicit in his SBS research when he said:<sup>15</sup>

"There exist major data gaps in the medical literature regarding SBS. These are summarised as:

- Lack of clear definition of cases. There is an urgent need for standard criteria, to identify certain cases for the purpose of

**The problem is the failure of medical professionals to recognise that vaccine adverse events do occur and that they are guilty of labelling them "coincidental" or "by chance".**

Continued on page 81





# GLOBAL EXPANSION TECTONICS

**Modern data analysis smashes the theory of plate tectonics by suggesting that the Earth has been expanding since Archaean times, particularly since the Early Jurassic period.**

by James Maxlow © 2000

Terrella Consultants  
Western Australia  
E-mail: [jmaxlow@enternet.com.au](mailto:jmaxlow@enternet.com.au)  
Website: [www.geocities.com/  
CapeCanaveral/Launchpad/6520/](http://www.geocities.com/CapeCanaveral/Launchpad/6520/)

*There is nothing more contentious in global tectonics at this time than the expanding Earth concept.*  
— Owen, 1992

**G**lobal tectonics was introduced a number of decades ago as an all-embracing science that seeks to quantify and explain the Earth as a dynamic, interactive entity. As an outcome of this new philosophy, we, in all our walks of life, have become accustomed to viewing the Earth globally, whether in relation to geology, ecology, climate, population, politics and so on.

Global tectonics, however, in its strictest geological sense, has become synonymous with plate tectonics, where all continents move across the Earth's surface under the action of mantle-driven convective currents. Each of the continents is supposedly in a state of random motion, periodically colliding, amalgamating, breaking up and dispersing during Earth history.

Global Expansion Tectonics is presented here as a viable alternative global tectonic explanation of geological phenomena, where the Earth has been expanding since the Archaean aeon and continents break up and disperse due to crustal extension, in an orderly, pre-determined manner. In making this statement, it must be realised that the concept of Earth expansion is not new; only the technology available to quantify an expansion process is. The global geological and geophysical information available for Earth dynamic studies has only now reached the stage where all global tectonic hypotheses, including plate tectonics, can be confidently quantified, challenged or discarded.

Earth expansionists, since the pioneering work of Christopher Otto Hilgenberg (1933) and, more recently, Professor Sam Warren Carey (1956, 1976, 1988, 1996) and Klaus Vogel (1983, 1990), have known that if all Earth's continents were fitted together they would neatly envelop the Earth with continental crust on a globe some 55% to 60% of its present size (the present mean radius of the Earth is 6,370.80 kilometres). This coincidence led Hilgenberg, Carey, Vogel and others to conclude that *terrestrial expansion brought about the splitting and gradual dispersal of continents as they moved radially outwards during geological time.*

However, this coincidence has consistently failed to gain recognition within the scientific community as a viable explanation for modern global tectonics. The primary reason for this non-acceptance in the past is considered to have been the lack of supportive global-scale evidence to quantify a reproducible expansion process with time. At present, scientists are so engrossed in forcing observational data into a singular plate-tectonic model that they are blissfully unaware that consideration of such a coincidence is necessary.

It has only been during the past two decades that global-scale data gathering, computer processing capabilities and electronic communication have advanced sufficiently enough to maintain and publicly distribute geological and geophysical data. Global Expansion Tectonics utilises this modern data and is introduced here as a revitalised concept of Earth expansion, which uses modern oceanic and continental geological mapping to constrain both ancient Earth radius and continental reconstruction from the Archaean aeon to the present. This data was not available to early researchers and, because of this, scientists could not be convinced that modelling studies or conclusions about Earth expansion were anything more than mere coincidence.

By using modern sea-floor mapping, Earth expansion can now be confidently modelled and constrained at reduced Earth radii by a simple process of progressive removal of sea-floor crust back to the Early Jurassic period (the age of the oldest sea-floor crust) and back further to the Archaean aeon by using continental geology.

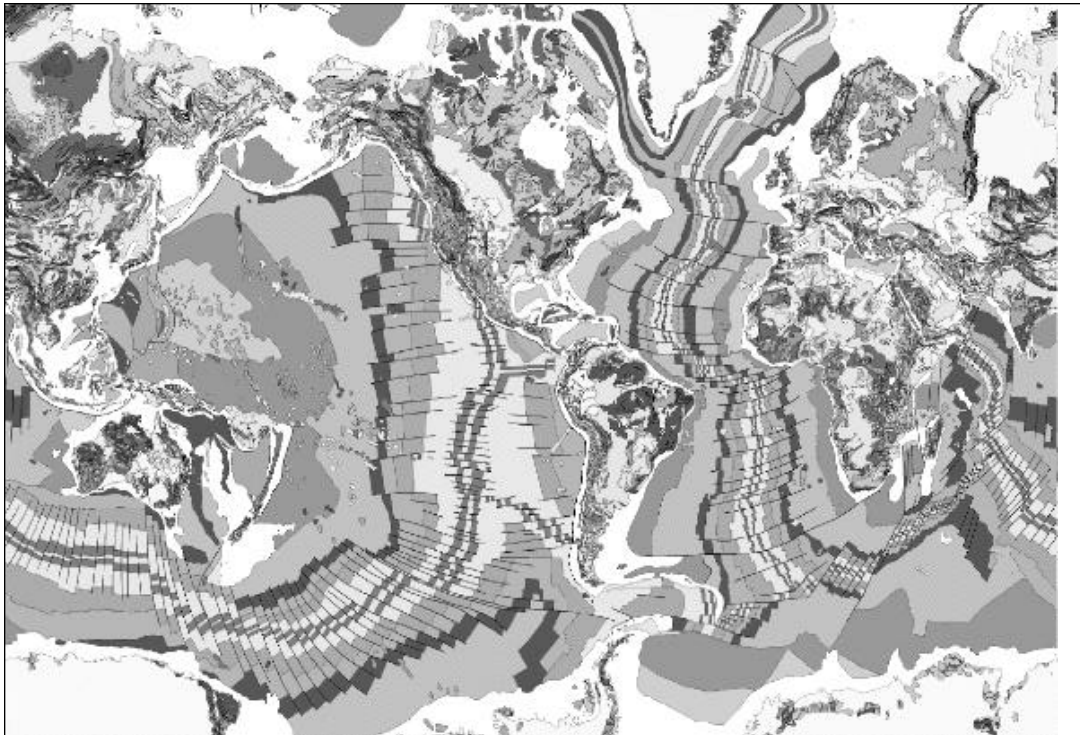

Figure 1. Bedrock geological map of the world showing continental and oceanic time-based geology. Oceanic mapping in each of the oceans represents the main geological periods, ranging from the Recent along the mid-ocean ridges to the Early Jurassic adjacent to the continents. The map is shown to 80 degrees north and south latitudes only. (After the *Geological Map of the World*, published by CGMW & UNESCO, 1990)

## GLOBAL EXPANSION TECTONICS

Empirical modelling and investigation into Earth expansion from the Archaean era to the present is based on the published *Bedrock Geology of the World* map (CGMW & UNESCO, 1990) (figure 1). The geology shown in this map is time-based, which means that the continental bedrock geology represents the major geological aeons (Archaean, Proterozoic) and eras (Palaeozoic, Mesozoic, Cenozoic), and oceanic geology represents the geological periods (subdivisions of the Mesozoic and Cenozoic eras) ranging from the Jurassic period to the Recent.

The oceanic geology shown in this map was compiled from magnetometer surveys, sea-floor drilling and radiometric and palaeontologic age-dating over the oceans, carried out during the 1960s to 1980s. Geophysical surveys covering all the world's oceans revealed long, linear, magnetic anomalies in the sea floor that are symmetrical about, and parallel to, mid-ocean ridges located centrally within each of the oceans. These anomalies were interpreted by geophysicists as evidence for sea-floor spreading, where mantle-derived lava wells up along the length of the ridge axes as the central spreading zones are continuously

widened. These magnetic anomalies have now been age-dated, and sea-floor mapping based on the magnetic anomalies is shown in figure 1.

The distribution of the oceanic geology demonstrates that all the oceans contain mid-ocean ridges, and distribution of geology symmetrical about, and parallel to, the mid-ocean-ridge axes demonstrates that the sea-floor crust ages away from the mid-ocean ridges, with the oldest Early Jurassic crust located adjacent to the continents. More importantly, the oceanic geology demonstrates that all the oceans are enlarging approximately normal to the ridge axes, and all continents are now moving away from each other as the sea floor enlarges.

The current rate of sea-floor spreading in each of the oceans varies between 1 to 10 centimetres per year.

To account for sea-floor spreading in all the oceans, though, we must consider the presumption that either:

(a) the Earth's radius has remained constant throughout geological time, and, to compensate for lava added along the spreading ridges, older pre-existing crust is continuously disposed of along inferred subduction zones located around the Pacific margin, displacing and recycling the crust into the mantle to maintain a constant total surface area, i.e., plate tectonics; or

(b) the Earth's radius has increased with time as lava is added at spreading ridges. In this concept, sea-floor crust older than the Early Jurassic period does not exist, subduction of crust is not required, and an increase in the Earth's surface area is a measure of the rate of change in the Earth's radius with time, i.e., Earth expansion.

To quantify Earth expansion, spherical models of the ancient Earth were constructed by progressively removing sea-floor crust parallel to the mid-ocean ridges and refitting the crust along each mid-ocean ridge at a reduced Earth radius. Each model shown in figure 2, for the Indian Ocean, and figure 3, for the Atlantic

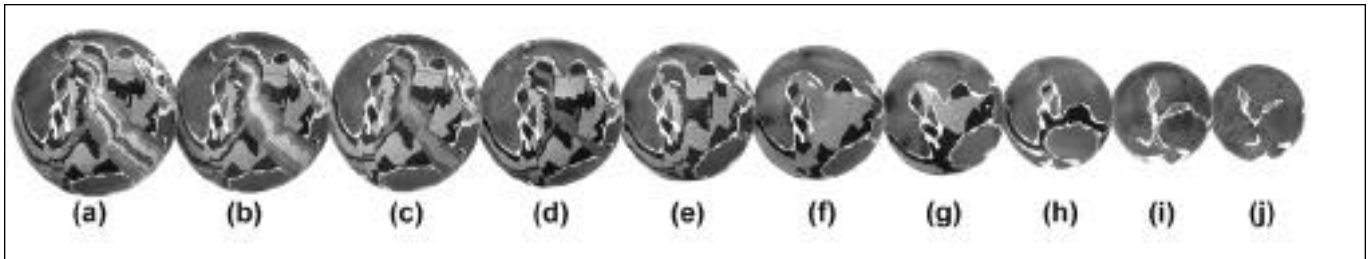

Figure 2. Expanding Earth reconstructions of the Indian Ocean for the beginning of the (a) Recent, (b) Pliocene, (c) Miocene, (d) Oligocene, (e) Eocene, (f) Palaeocene, (g) Late Cretaceous, (h) Mid Cretaceous, (i) Early Cretaceous and (j) Late Jurassic periods. Each ancient Earth model was constructed by progressive removal of sea-floor crust, shown in figure 1, and reuniting plates along each mid-ocean ridge at a reduced Earth radius.

Ocean, demonstrates that all crustal plates assemble with a better than 99% fit-together, and all plates are accurately constrained. This construction method was continued back to the Early Jurassic period, about 160 million years before the present, until all sea-floor crust was removed. At this time, all continents were refitted together, like a spherical jigsaw puzzle, at about 62% of the present Earth radius, or about 3,540 kilometres.

By removing all the sea-floor crust, plus sediments deposited around the continental margins (shown as white margins in figures 2 and 3), all the continents can be united as a single continental shell encompassing the entire Earth at a radius of 50% of the present Earth radius during the Permian period, about 260 million years ago. By progressively removing sediments from continental sedimentary basins, each of the ancient Archaean and Proterozoic regions of the continents can also be assembled as a primordial Earth at approximately 27% of the present Earth radius during the Early Proterozoic aeon, about 1,600 million years ago (not shown in figures 2 and 3).

### FREQUENTLY ASKED QUESTIONS

Acceptance of Earth expansion as a viable global tectonic process is currently envisaged by researchers from many countries to be thwarted by major obstacles which supposedly *outnumber the evidence in favour*. These opinions are based on outdated research carried out during the 1950s to 1970s, well before the advent of modern global tectonics, computer technology, global data-gathering capabilities and multimedia communication. Unfortunately, these same outdated opinions are being carried through to recent literature without proper scientific investigation, regardless of advances made in Earth expansion.

The most commonly perceived problems include: an explanation for the cause of Earth expansion; the problem of ocean water and atmosphere accumulation on an expanding Earth; and palaeomagnetic determinations of ancient pole locations and Earth radius. Frequently asked questions about Earth expansion include:

- **Where does the additional mass come from?**

This is a very important but very difficult question to answer. Because the Earth has always been considered as being the same size since creation, from either a religious or a cosmological point of view, it has not been necessary to ask the question. Because

the question has not been asked or taken seriously, where the additional mass comes from remains speculative. This question, however, must be asked in the same context as the additional question: where does the mass of the Universe come from? The answers to both questions are synonymous.

Mathematical studies based on modelling research demonstrate that the Earth is indeed expanding because of an increase in mass with time. What this study also tells us is that the mean density of the Earth has remained constant, or near constant, since creation, and, of importance to life on Earth, the surface gravity has been steadily increasing with time. The surface gravity during the dinosaur era, for instance, is calculated to be approximately half

the present value, hence dinosaurs were bigger, longer and heavier than they could ever be on Earth today.

The ultimate cause of Earth expansion was considered by Professor Carey (Carey, 1996) to be intimately related to a cosmological expansion of the Universe. He considered that, based on Albert Einstein's famous equation,  $E = mc^2$ , the creation of mass occurs as a result of a condensation of energy. Professor Carey concluded that matter is being created deep within the Earth's core. While speculative, it is envisaged that matter condensing at the core-mantle boundary would then result in a swelling of the mantle, which in turn would cause expansion of the Earth. This is then reflected at the Earth's surface by continental crustal extension, and when extension reaches a critical stage, as happened during the Permian period, the continents break up and disperse, exactly as we see in figures 2 and 3.

- **What about the pre-Triassic?**

On an expanding Earth prior to the Triassic period about 245 million years ago, modern deep oceans did not exist. All continental crust was united to

form a single supercontinent called Pangaea, enclosing the ancient Earth at a radius of about 3,200 kilometres—50% of the size of the present radius.

Geographical studies show that oceans during the pre-Triassic period were represented by a network of continental seas, with deposition of sediments within continental sedimentary basins masking all evidence of sea-floor spreading. Exposed lands and varying coastal outlines during the Early Palaeozoic era were represented by the ancient Gondwana, Laurentia, Baltica and Laurussia continents, and during the Proterozoic aeon by the

**The surface gravity during the dinosaur era, for instance, is calculated to be approximately half the present value, hence dinosaurs were bigger, longer and heavier than they could ever be on Earth today.**



Figure 3. Expanding Earth reconstructions of the Atlantic Ocean for the beginning of the (a) Recent, (b) Pliocene, (c) Miocene, (d) Oligocene, (e) Eocene, (f) Palaeocene, (g) Late Cretaceous, (h) Mid Cretaceous, (i) Early Cretaceous and (j) Late Jurassic periods. Each ancient Earth model shows a progressive break-up and dispersal of continents, resulting in the pattern of sea-floor geology shown in figure 1.

ancient Rodinia supercontinent. These ancient continental assemblages and intervening seas agree in principle with conventional plate tectonic assemblages, without the requirement for extensive ancient Panthallassa and Tethys oceans. The significance to global tectonics is that—without the extensive Panthallassa and Tethys oceans—climatic zonation, geography, distribution and migration routes of marine and terrestrial life-forms are dramatically simplified.

Modelling studies indicate that the primordial Earth size for the Archaean aeon was approximately 1,700 kilometres in radius and remained relatively static throughout the Archaean to the Late Mesoproterozoic era, increasing by approximately 60 kilometres during 3,000 million years of Earth history. Since the Proterozoic aeon, there has been a steady to rapidly accelerating expansion to the present. The present rate of radial Earth expansion is calculated to be 22 millimetres per year, which equates to a 140 mm/year increase in circumference.

• **What about the ocean water and atmosphere?**

Researchers have argued that before the Triassic period an ancient Earth with a continuous continental crust would be covered by an ocean with an average depth of 6.3 kilometres. If this were the case, then terrestrial life-forms would not have evolved and continents would have only been exposed to erosion fairly recently in Earth history. However, all continents contain

sedimentary rocks dating back to over 3,000 million years ago, and fossilised life-forms dating back to the beginning of the Cambrian period, about 560 million years ago, abound in our museums of natural history.

On an expanding Earth, the ocean water and atmosphere were added at the same time and rate as the sea-floor crust and underlying mantle were added. Modern investigations along active rift zones demonstrate that these, as well as volcanoes, are major sources of new water and gases. The sea-floor crust, ocean water and atmosphere all originate from deep within the Earth's mantle and have been added to the surface crust at an accelerating rate throughout geological time. This increase in new ocean water and atmosphere is considered to have resulted by a process of mantle outgassing, as a natural response to a decrease in mantle temperature and pressure conditions with time.

• **What about subduction?**

On a constant-radius Earth, sea-floor crust generated along each of the mid-ocean ridges must be disposed of somewhere. Early researchers considered that crust was being subducted around the margins of the Pacific Ocean, and the apparent overriding of the North Pacific Ocean plate by North America and Australia is often quoted as a classic example of plate consumption by subduction. Here, up to 5,000 to 15,000 kilometres of North Pacific Ocean sea-floor crust has supposedly been subducted beneath the

North American continent, and the surface area of the Pacific Ocean has supposedly decreased as the Indian, Atlantic and Southern oceans have opened.

The history of the Mesozoic and Cenozoic eras has then supposedly been one of east-west and north-south contraction of ancient Panthallassa and Tethys oceans to the size of the modern Pacific Ocean, subduction of all pre-Mesozoic sea-floor crust, and subduction of a substantial quantity of sea-floor crust generated during the Mesozoic and Cenozoic eras.

Since the introduction of the plate tectonic hypothesis, magnetic mapping of the oceans has revealed that, as well as sea-floor spreading in the Indian, Atlantic, Southern and Arctic oceans, the Pacific Ocean is also undergoing extensive sea-floor spreading, right where subduction around the margins is supposedly taking place (see figure 1). Plate motion measurements

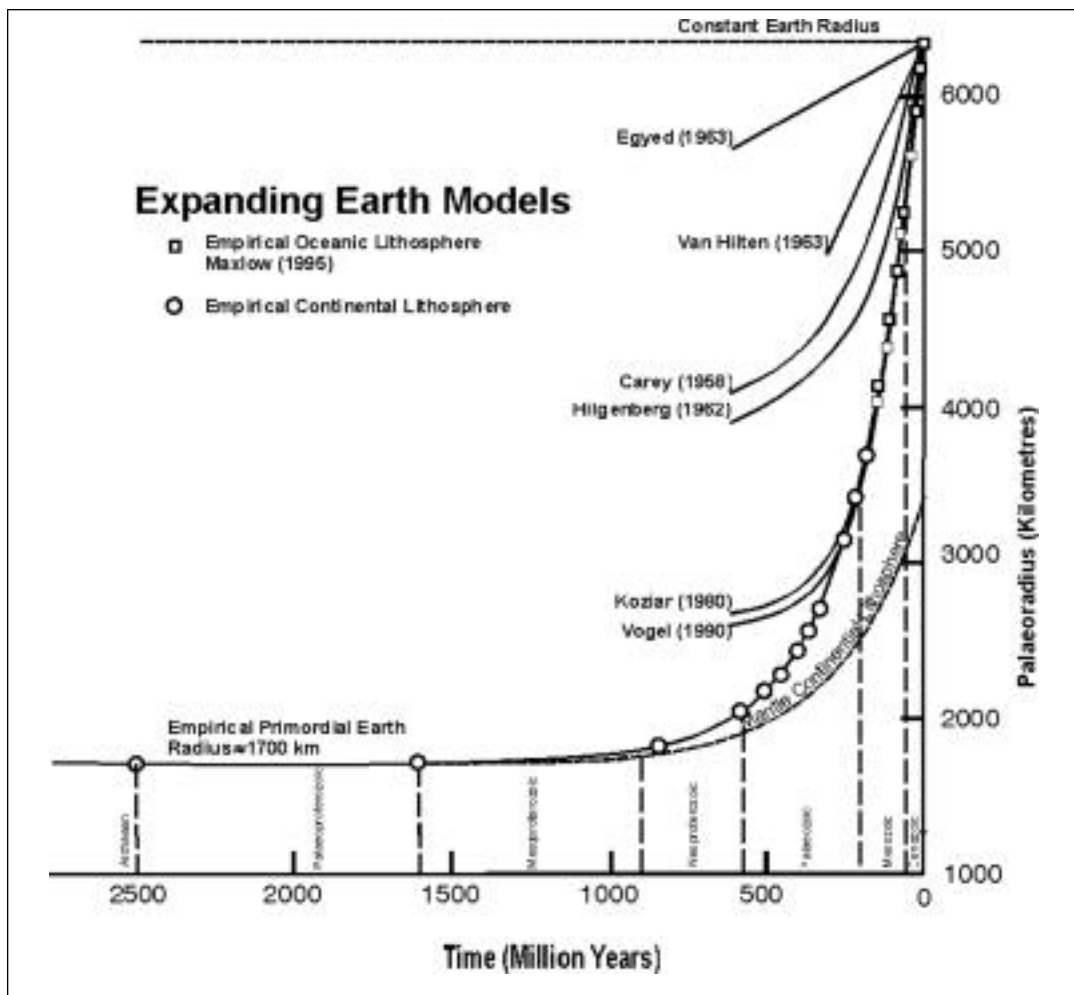

Figure 4. Exponential Earth expansion from the Archaean to the present. Graph shows post-Triassic expansion derived from oceanic mapping and pre-Jurassic expansion derived from an Archaean primordial Earth radius of approximately 1,700 kilometres. Spherical expanding Earth models constructed are shown as filled squares and circles on the graph.

using satellite laser ranging and radio astronomy are now accurate to less than one centimetre. These measurements show that the North American plate is moving west at about 16 mm/year, while the North Pacific plate is moving west-northwest at between 45 and 70 mm/year. The sum of these motion vectors means that the two plates are actually moving apart, not subducting, and the East Pacific mid-ocean-rift zone is extending north along the San Andreas fault (see figure 1).

On an expanding Earth, subduction to the extent that plate tectonics requires does not exist. The values of 22 mm/year, calculated for increase in Earth radius per year, and 140 mm/year for circumference, are adequate to account for all sea-floor growth since the Early Jurassic period, without the need to consider removal of excess sea-floor crust.

#### • What about orogenesis?

The term *orogeny*, or *orogenesis*, originally meant "the origin of mountains". Since the advent of plate tectonics, orogenesis has come to mean "the folding of rocks in fold belts", not mountain-building. Confusion in the literature persists, however, and it is generally assumed that folding results from continental collision, and collision results in mountain-building. In the real world, mountains are eroded plateaus and are created by vertical movement and modified by erosion.

Researchers have considered that because Earth expansion is a radial process, then orogenesis caused by continental collision, and hence mountain-building, cannot occur. Earth expansion was then discounted because the radial expansion process did not appear to explain the compression required for continental collision, nor the compression required for orogenesis.

On an expanding Earth, orogenesis means "folding of rocks to form fold belts". During expansion, the continental crust must distort, bend, twist and turn to adjust continuously for the change in surface curvature. During this crustal movement there is folding of the soft sediments within sedimentary basins, accompanied by faulting, volcanic intrusion and metamorphism (heating and compression of the rocks), resulting in orogenesis. Once the continents broke up and started to disperse during the Mesozoic era, the edges of the continents started to rise as the interior collapsed during changing surface curvature. Throughout the world today, we now see great escarpment mountains along many of our continental margins, with no need for continental collision, and wide, relatively flat inland plains.

#### • What about palaeomagnetism?

In palaeomagnetism, measurements of remnant magnetism residing in rocks containing iron minerals are made to determine the ancient latitude of a site sample and the direction to the ancient magnetic pole. These measurements have long been considered the cornerstone of plate tectonics. They are routinely used to determine ancient pole positions to constrain reconstructions of ancient continental assemblages, and have also been used to

determine the ancient radius of the Earth. From measurements of the ancient radius, it was concluded that the radius of the Earth has remained constant with time. This conclusion continues to be a key issue in rejecting Earth expansion.

In establishing palaeomagnetism, geophysicists during the early 1960s made a fundamental assumption that the surface area of all continents has remained constant with time, with continental crust being added or removed from around the margins during continental collision or break-up. In determining the ancient Earth radius, palaeomagnetic measurements were taken from sites separated by up to 5,000 kilometres, and it was assumed that the continental crust between the sites had remained constant and stable. Modern plate tectonics now says that continents are made up of fragments randomly accreted during continental assemblage, break-up and dispersal cycles—which makes the conclusions based on ancient radius measurements invalid.

Modelling studies have demonstrated that ancient magnetic poles, determined from palaeomagnetic data, when plotted on expanding Earth models, cluster as diametrically opposed north and south poles. These pole locations show that the ancient North Pole was located in Mongolia to northern China during the Precambrian and Palaeozoic eras, prior to moving north to its present location as the continents migrated south. The ancient South Pole was located in western central Africa throughout the Precambrian and Palaeozoic, prior to moving south to its present location as the continents migrated north.

**These pole locations show that the ancient North Pole was located in Mongolia to northern China during the Precambrian and Palaeozoic eras, prior to moving north to its present location as the continents migrated south.**

#### • What about space geodesics?

Space geodesics is modern technology that uses VLBI (very long baseline interferometry), SLR (satellite laser ranging), GPS (global positioning systems), DORIS (Doppler orbitography and radiopositioning integrated by satellite) and LLR (lunar laser ranging) to measure the dimensions of the Earth and plate motions of the continents to sub-centimetre accuracy. This technology has determined that the radius of the Earth is increasing by less than  $5 \pm 3$  mm/year, or in other words is shown to be "constant". This effectively replaces palaeomagnetism as the main

argument against Earth expansion.

In order to determine Earth radius using VLBI, two or more ground stations are used to determine Earth parameters in relation to a very accurate celestial reference frame. These measurements are then converted to an international terrestrial reference frame and used with measurements using satellite technology to calculate a global solution. The limitations to all methods, and VLBI in particular, are atmospheric interference and, for the satellite methods, the use of the physical constants  $G$  (universal gravitation) and  $M$  (Earth mass) to tie orbital parameters to the centre of the Earth.

When enough VLBI ground stations were established to form a global network during the early 1990s, it was found that the global excess in radius was 18 mm/year (Robaudo & Harrison, 1993). This value was considered to be extremely high when compared to expected deglaciation rates, estimated at less than 10 mm/year.

Robaudo and Harrison in fact "expected that most VLBI stations will have up-down motions of only a few mm/yr" and recommended that the vertical motion be "restricted to zero, because this is closer to the true situation than an average motion of 18 mm/yr" (Robaudo & Harrison, 1993, p. 54). This recommendation is now reflected in current solutions to the global network where global solutions are effectively constrained to zero.

The recommendations of Robaudo and Harrison are justified from a plate tectonic perspective. The 18 mm/year excess was considered to be an error in atmospheric correction, so was simply adjusted accordingly. What must be appreciated is that without an acknowledgment of a potential increase in Earth radius, NASA had no option but to correct this value to zero and hence adopt a static Earth radius premise. From an expanding Earth point of view, however, the 18 mm/year excess equates with the 22 mm/year required for Earth expansion, determined from measurements of areas of sea-floor spreading.

**In order to accept Global Expansion Tectonics as a viable global tectonic process, we must be prepared, however, to remove the "blinkers of dogma" so prevalent in our learned institutions, in order to encourage active research into alternatives to accepted global tectonics.**

#### A VIABLE GLOBAL TECTONICS EXPLANATION

While the cause of Earth expansion remains a speculative issue, in time this will be resolved by dedicated research. The geophysical objections to Earth expansion outlined above can only be resolved by an acceptance of the potential for expansion and adequate scientific resolution. The only limitations to Earth expansion relate to limitations in technical ability to display global-scale geological and geophysical information in an interactive 4-D spherical format, and I am sure there are wise and wonderful people out there who are more than capable of doing that.

By using the published oceanic and continental geological mapping shown in the *Geological Map of the World* (CGMW & UNESCO, 1990), the process of Earth expansion from the Archaean aeon to the present can now be accurately constrained. This in itself quantifies Earth expansion. By creating models from this mapping, the expansion process can be readily visualised throughout Earth history. The ancient Earth was shown to undergo a steady expansion throughout the Archaean and

Proterozoic, prior to a rapidly accelerating expansion during the Palaeozoic era, and continental break-up and dispersal during the Mesozoic and Cenozoic eras to the present.

Readily available geophysical and geological data plotted on each of the models demonstrates that the ancient equator, determined from the ancient pole positions, agrees in principle with plate tectonic locations using palaeomagnetic and climatic data. Ancient polar ice-caps, limestone reefs, coal deposits, vegetation patterns, and marine and terrestrial life-forms all coincide with the ancient equator and pole positions throughout

Earth history. This coincidence is an impossibility on an Earth of constant radius.

This modern geological and geophysical data can now be used to accurately quantify Earth expansion, making the evidence for expansion very favourable.

In order to accept Global Expansion Tectonics as a viable global tectonic process, we must be prepared, however, to remove the "blinkers of dogma" so prevalent in our learned institutions, in order to encourage active research into alternatives to accepted global tectonics.

#### References

- Carey, S.W. (1956), "The tectonic approach to continental drift", in *Continental Drift, A Symposium*, University of Tasmania, Hobart, pp. 177-355.
- Carey, S.W., *The Expanding Earth*, Elsevier, Amsterdam, 1976 (488pp.).
- Carey, S.W., *Theories of the Earth and Universe: A History of Dogma in the Earth Sciences*, Stanford University Press, Stanford, California, 1988.
- Carey, S.W., *Earth, Universe, Cosmos*, University of Tasmania, Hobart, 1996 (204pp.).
- CGMW and UNESCO, *Geological Map of the World*, Commission for the Geological Map of the World, Paris, 1990.
- Eged, L. (1963), "The Expanding Earth?", *Nature* 197:1059-1060.
- Hilgenberg, O.C., *Vom wachsenden Erdball*, Selbstverlag, Berlin, 1933 (50pp.).
- Hilgenberg, O.C. (1962), "Paläopollagen der Erde", *Neues Jahrb. Geol. und Paläontol.*, Abhandl 116, Stuttgart.
- Koziar, J. (1980), "Ekspansja den oceanicznych I jej zwiazek z hipoteza ekspansji Ziemi", *Sprawozdania Wroclawskiego Towarzystwa Naukowego* 35B:13-19.
- Maxlow (1995), "Global Expansion Tectonics: the geological implications of an expanding Earth", unpublished thesis, Curtin University of Technology, Perth, Western Australia (268pp.).
- Owen, H.G., "Has the Earth increased in size?", in S. Chatterjee and N. Holton III (eds), *New Concepts in Global Tectonics*, Texas Technical University Press, USA, 1992, pp. 289-296.
- Robaudo, S. and Harrison, C.G.A., 1993, "Plate tectonics from SLR and VLBI global data", in D.E. Smith and D.L. Turcotte (eds), *Contributions of Space Geodesy to Geodynamics: Crustal Dynamics*, Geodynamics Series, American Geophysical Union, volume 23, 1993.
- Van Hilten, D. (1963), "Palaeomagnetic indications of an increase in the Earth's radius", *Nature* 200:1277-1279.
- Vogel, K., "Global models and Earth expansion", in S.W. Carey (ed.), *Expanding Earth Symposium, Sydney, 1981*, University of Tasmania, 1983, pp. 17-27.
- Vogel, K., "The expansion of the Earth – an alternative model to the plate tectonics theory", in *Critical Aspects of the Plate Tectonics Theory; Volume II, Alternative Theories*, Theophrastus Publishers, Athens, Greece, 1990, pp. 14-34.

#### About the Author:

James Maxlow is a geologist with over 25 years' field exploration/mining experience. He has a Master's degree in geology and is currently completing a PhD in geology. He is principal researcher with Terrella Consultants, a Western Australian-based geological consultancy dedicated to research into and promotion of Global Expansion Tectonics. The consultancy values and encourages professional input from a worldwide network of Earth expansion researchers.

For further information and/or input, e-mail the author at [jmaxlow@enternet.com.au](mailto:jmaxlow@enternet.com.au) or visit his website, [www.geocities.com/CapeCanaveral/Launchpad/6520/](http://www.geocities.com/CapeCanaveral/Launchpad/6520/).







### CALLOWAY HIGH-EFFICIENCY COLLECTOR CIRCUIT

from KeelyNet © 2000

#### BUILD THIS AT YOUR OWN RISK!

This circuit is a design used by Robert Calloway, based on John Bedini's over-unity motor and energy collection experiments posted on his website, [www.icehouse.net/john1](http://www.icehouse.net/john1).

Here is the redrawn circuit that Robert so kindly shared. He indicates it will allow collection of sufficient energy from a rotating magnet arrangement as to provide one watt of excess energy above and beyond what it takes to recharge the battery.

If you choose to experiment with such devices and wish to share your findings, advice or any anomalies, please direct your comments to Robert Calloway or to Jerry Decker so they can be posted and archived publicly in the KeelyNet Interact discussion list. It's only when we share that everyone learns.

The following circuit had an error when I first posted it on 9 August 2000, which was

caught by Ken Carrigan. The circuit has now been corrected; thanks Ken.

The battery is a 9-volt DC transistor battery. Coil construction and other details can be found in the report on the 10-year-old girl's science fair project below [also see Bedini article, Science News, NEXUS 7/04]. I will integrate as much as I can into this file as information is provided.

The S1 switch gives you the option of whether or not you want to recharge the battery. I'm not sure why you would want to do that, other than to *drain* a fully charged battery by seeing how long the motor would run without recharging. Replace the battery with a new one, and then switch the charging circuit on and see how much longer the motor runs *with recharging*.

In the case of Bedini's 10-year-old girl who won the science fair with her version of his motor, with recharging the motor reportedly ran at 4,000 rpm for five days, and the 9-volt transistor battery was still fully charged when they shut it down at the end of the science fair. That is, to say the

least, *highly efficient*.

Note: you will have to experiment with the number of magnets and coils as well as their placement to achieve the best operation.

Jerry Decker, KeelyNet, 9 August 2000

#### Robert Calloway's comments

9 August 2000, 6.46 pm

Hello, Jerry: I see nothing wrong with the circuit; a job well done! The single diode is the 6-amp blocking type. Probably an overkill, but I got it at work. The bridge is a 400-volt at 2 amps. The coils are 370 turns of #19 magnetic wire. The cores are very important.

For the fellow just starting out for an easy-put-together motor, use 5/16 mild steel bolts by 2 inches long. Check these bolts with a magnet; make sure they do not retain magnetism. Wrap the shoulder of the bolt with one layer of electrical tape.

Find some leftover plexiglass somewhere and take a 2-inch hole saw and cut out two plugs per coil. Slide one of the plugs onto the bolt to the head, then slide the other one onto the shoulder of the bolt. Having the shoulder of the bolt wrapped to protect the wire, start winding.

Make sure you wind both coils in the same direction. The resistance in the coil is about 0.6 to 0.7 ohms. The threaded portion of the now-made coil can be used for easy mounting.

For the serious builder, use mild steel filings mixed with epoxy for the cores. This must be a heavy mix of metal with the epoxy. A plastic spool with about a 5/16 hollow centre works well with this application.

Jerry, I will attach a picture to this message which will help anyone get the idea of how to build this motor. However, it is my first prototype. Different coils and timing were used then. This picture is not what I use now, but it may help—your choice.

I am also concerned with folks that are trying to build a motor and really don't know a lot about circuits or using plain common sense. Please, put in a clause that says "Build at your own risk!" or something to that effect. I have had several

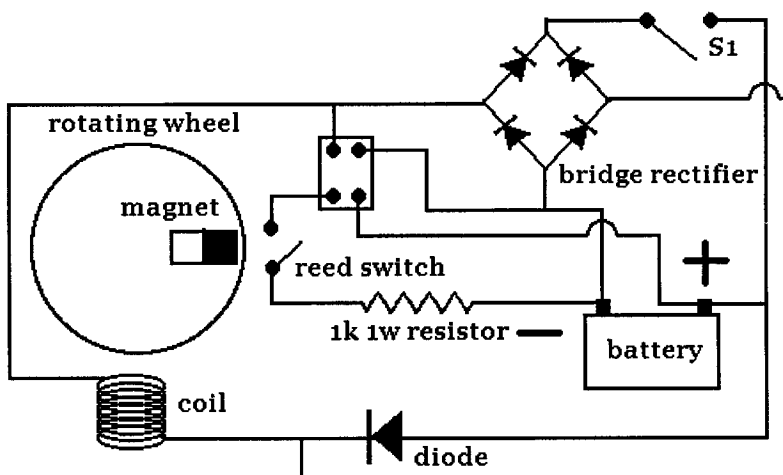

reed switch is normally open  
 solid state (3-33vdc) relay is normally open RLYB1210D Phillips  
 1kohm 1watt resistor protects reed relay  
 S1 on/off switch is optional

coil and reed switch positions must be adjusted for best results

phone calls and e-mails that verify that...

I also recommend the air gap between the magnet and stator coils be no closer than 5/32 starting out, for safety. Get timing adjusted, get used to the motor, then play with the air gap. This motor can do some strange things with a close air gap.

I now place the reed switch down on the base of the motor and let the rotor magnets activate it. This does away with the complicated timing stuff on the end of the shaft. When I get the funds together, my dream is to build a 16-pole motor that uses 8 stator coils. It will be a twin-disc rotor that utilises both ends of the stator coils.

Almost forgot. Keep the pulses short from the reed switch. One can move the reed switch around on the base to achieve this. If you have got the pulses as short as you can get and need them shorter, place a piece of thin iron between the reed and the magnets. Remember, if your pulses are a fraction too long, this is wasted energy.

You can also add two extra magnets to the rotor for more power to the rotor shaft; place them 90 degrees apart. Remember, that poor reed switch will be working four times per revolution then. The two stator coils should be hooked up in parallel, but it will work hooked up in series.

Regards, Robert

## Robert Calloway's comments 9 August 2000, 8.49 pm

Hello, Jerry: I forgot one very important thing: the rotor flywheel. Mine is a 7-1/4-inch grinding disc rated for 8,400 rpm. The weight is 7 lbs with the magnets glued to it. Do not use field coils on the rim to collect current! This is a *big no-no*.

The flywheel effect must be used with this design. Use the rotor shaft to drive a generator instead. A 5/8 all thread shaft will screw right through the grinding disc with a nut to lock it in place. Then it is very easy to adjust magnet to stator gap with this set-up.

Robert

## Robert Calloway's comments 10 August 2000, 5.40 pm

Hello, Jerry: Sorry for all the confusion. The motor is not a Bedini design. It is based on the principles of his design and the Adams design. It is also a 12-volt system using a 4 ah (amp hour) gel cel battery.

Robert

(Source: KeelyNet, [www.keelynet.com/bedmot/callow1.htm](http://www.keelynet.com/bedmot/callow1.htm))

## A NEW THEORY OF GRAVITY A Brief Introduction

by David W. Allan © 2000

*Physicists have already brought most of the forces of nature into a single underlying theory. The ultimate theory will incorporate gravity as well.*

— Steven Weinberg

*Time*, 10 April 2000, p. 86

One of the biggest questions that has puzzled mankind throughout the ages is how gravity works. This new gravitational theory not only explains how gravity works, but shows how errors can arise in determining the positions of space probes, in determining the mass of the Earth and other planets and in determining the value of  $G$ , the universal gravitational constant.

This new theory of gravity is part of a more general Unified Field Theory (UFT) that shows how all of the known force-fields work together. Once understood, this new UFT explains several heretofore unexplained phenomena in nature. In this brief write-up, we will only deal with the gravitational part of the UFT.

John Anderson and colleagues of NASA JPL, experts in the determination of spacecraft positioning, have published discrepancies observed in the locations of *Pioneer 10*, *Pioneer 11* and the *Ulysses* solar probe (Anderson, 1998; Katz, 1999; Murphy, 1999). To date, these discrepancies have not been fully explained. Anderson has raised the question as to whether there is a fundamental problem in our understanding of gravity or in the timing provided by the atomic clocks as part of the Deep Space Network (DSN) which tracks the space probes. The space vehicles exhibit a pull toward the Sun, greater than current theory would predict by about  $2e^{-8}$  cm/s<sup>2</sup>.

The general model now being used to describe the gravitational field proposes that gravitational waves run transverse to the direction of propagation of the gravitational energy. As predicted by Einstein, gravitational energy would travel at the velocity of light. To date, no experiments have been able to measure gravitational waves directly or even detect them; but, from the interaction of the gravitational forces between a binary pulsar pair, Prof. Joseph Taylor (Princeton University) was able to deduce Einstein's prediction that the gravitational energy travels at the velocity of light (Taylor, 1994).

Currently, many hundreds of millions of dollars have been spent, and hundreds of millions are now being sought, by an international university and investigative consortium in order to continue their research into gravity waves and to unravel the mysteries of gravity.

It is our hope and belief that our work will bring further enlightenment to this challenge and provide the necessary, but different, perspective needed to understand gravity.

The most significant aspect of this new theory is the discovery of *diallel, gravitational-field lines*. These diallel lines open up a whole new paradigm and help to explain several heretofore unexplainable problems in physics. With a new perspective, we need some new physics. Papers are in preparation for publication to explain some of this new physics, and some information is available on our website, [www.allanstime.com](http://www.allanstime.com).

In this new theory, two things are required for gravity to work. Firstly, two bodies of some *energy density* to interact with each other; and secondly, connecting diallel lines, which provide not only particle flow between the bodies but also the flow of photon and gravitational information.

In chemistry and molecular spectroscopy, we take for granted the seven electron shells that describe the energy states of electrons in their various atomic and molecular configurations. These seven shells, along with the number of protons, neutrons and electrons, give us all of our elements and isotopes of which we are aware. As these seven shells include all the electrons' configurations around an atom or molecule, similarly *there are seven channels or states of conductivity for the diallel lines* included in the new theory of gravity and in the UFT. *These diallel lines are made of the same matter, and can serve as a conduit for any and all of the fundamental particles as well as for photons.*

The diallel lines are the conduits for the gravity information as well, bringing about the interaction between the two bodies. Just as a magnetic field requires no particles to make the field, so there is no graviton required to make a gravity field. In the same way that a moving charge sets up a condition for the generation of a magnetic field, a certain set of conditions will generate a gravitational field. The minimum conditions require two bodies, each with some level of energy density, together with

# NEWSCIENCE NEWSCIENCE NEWSCIENCE

a flow of charged particles along the diallel lines connecting these two bodies. The moving charges and particles in the diallel lines set up the necessary conditions for the gravitational information to flow between the two bodies providing the gravitational interaction. The velocity of the gravitational information is a function of the conditions—typically, at or faster than the velocity of light.

The frequency of this gravitational information is located in a band just above that of the cosmic rays that are associated with particle annihilation and generation. Like light, the velocity of gravity information is dependent on local circumstances.

In the same manner that photons are associated with quantum transitions and all particles exist (interactively) in quantum states, the diallel lines have quantum states in which both particles and gravitational information travel. As particles and photons can be absorbed, refracted or reflected, so can diallel lines when given the right local circumstances.

A classic illustration of the refraction or bending of these diallel lines was determined by a team from the University of Alaska who observed the bending of electron flow above extremely energetic thunderstorm activities.

As will be seen below, the equations of state describing the fields for diallel lines contain the possibility for sign reversal, i.e., antigravity or gravitational shielding.

Some additional perspectives are useful to appreciate aspects of the new physics needed for this new theory. We have long established in quantum physics the dual nature of matter: a particle can behave like a wave. Similarly, a photon, which is basically an electromagnetic bundle of energy oscillating at a particular frequency, can also behave as a particle. The electromagnetic field associated with a photon has no charge, and its energy is proportional to its frequency. The gravitational information cannot be considered as a particle or a bundle of energy *per se*. Operating above the cosmic frequency band, this gravitational information is communicated in a way not heretofore appreciated. We cannot write  $E = h\nu$  to describe its energy, and we need a new set of equations associated with this flow of information.

In summary, then, the conditions needed for the gravitational field are two objects with some energy density (not just mass) and with diallel lines running between these two energy-density objects—which

diallel lines are conducting particles, i.e., electrons, protons, neutrons, etc. These diallel lines then provide a conduit for the gravitational band of frequencies to communicate and generate a gravitational interaction between the two objects. Much like our circulatory and respiratory systems breathe and pulse to sustain life, so these diallel lines are the communication channels to provide (in analogy with breath and pulse) a balance and harmony and the function of nature.

The traditional gravitational equation is:

$$F = G \frac{m_1 m_2}{r_{12}^2}$$

The product of the masses is divided by the distance between them squared, and  $G$  is the well-known constant of proportionality, the universal gravitational constant. According to this equation, the acceleration of gravity that we feel on the Earth is given by  $Gm_1/r_{12}^2$  ( $= 9.8 \text{ m/s}^2$  nominally at the surface of the Earth), if  $m_1$  is the mass of the Earth and  $m_2$  is the mass of the person feeling the acceleration. What we feel when standing is nominally this force, since we are constrained to walk about on the Earth. If the material surface of the Earth were not constraining us, we would then free-fall, accelerating toward the centre of mass of the Earth.

Given the new theory, the attraction is a function of the energy density, which, of course, includes the mass. The above traditional equation is a subset of the new. The *new equation* for gravitational force replaces the masses by the integral over the density, and is as follows:

$$F = \frac{1}{c^2 G r_{12}^2} \int_{V_1}^{V_1+1} E_1 / \Omega_1 dV \int_{V_2}^{V_2+1} E_2 / \Omega_2 dV$$

It is fascinating that at CU, where they have created new matter called Bose-Einstein condensate, the velocity of light in this condensate can be almost as slow as the velocity of sound. It would be instructive to perform diallel line experiments in conjunction with B-E condensate matter. This high-density material could lead to some interesting validations of this new UFT due to the higher energy densities present.

The work of Dr Ning Li at the University of Alabama at Huntsville is particularly fascinating also, as she is doing high-frequency work with superconductors and investigating the quantum states associated with the gravity fields. She has not yet

published her full theory, and her work appears to be among the most promising (see references below).

As the electrons travel along diallel lines, they spin clockwise in a variety of quantum states. Antigravity comes as a result of spinning the electrons in the opposite direction. This is like and in conjunction with the creation of antimatter. By so doing, one gets a negative sign from the  $A_2$  term in the above equation; for example, creating an upward rather than a downward force. This is somewhat analogous to a magnetic field being used to suspend objects.

Papers are available on the UFT, and both validating experiments and theory for the above gravitational interaction are available. These papers may be obtained by request. Several experiments are planned and some now are being prepared.

## Bibliography

- Anderson, J. et al., *Physical Review Letters* 81(14), 5 October 1998.
- Katz, J.I., *Physical Review Letters* 83(9), 30 August 1999.
- Murphy, E.M., *Physical Review Letters* 83(9), 30 August 1999.
- Taylor, J., "Binary Pulsars and Relativistic Gravity", *Reviews of Modern Physics* 66:711, 1994 (Nobel Prize).

## Related Papers

- Li, Ning and D.G. Torr, *Physical Review* 43D:457, 1991.
- Li, Ning and D.G. Torr, *Physical Review* 46B:5489, 1992.
- Li, Ning and D.G. Torr, *Bulletin of American Physical Society* 37:948, 1992.
- Podkletnov, E. and R. Nieminen, *Physica C* 203:441, 1992.
- Torr, D.G. and Ning Li, *Found. Physics Letters* 37:948, 1993.

## Related Websites

- Gravity.org, a website presenting various scientific findings regarding gravity alteration.
- The University of Alaska has several papers on "red sprites" and "blue jets" at website <http://sprite.gi.alaska.edu/>.

## Editor's Note:

This article was downloaded from David W. Allan's website, <http://www.allanstime.com>, Allan's Time Interval Metrology Enterprises, PO Box 66, Fountain Green, Utah 84642, USA, fax +1 (435) 835 1625.



# — THE EVIDENCE FOR — ANCIENT ATOMIC WARFARE

*Religious texts  
and geological  
evidence suggest  
that several parts  
of the world have  
experienced  
destructive  
atomic blasts in  
ages past.*

**Part 2 of 2**

by David Hatcher Childress © 2000

Extracted from Chapter 6 of his book  
*Technology of the Gods: The Incredible  
Sciences of the Ancients*

Published by  
Adventures Unlimited Press  
Kempton, Illinois, USA  
Website: [www.adventuresunlimited.co.nz](http://www.adventuresunlimited.co.nz)

## VITRIFIED RUINS IN CALIFORNIA'S DEATH VALLEY

It seems one local character knew how to find the place. Brandon relates that "Death Valley Scotty", an eccentric who spent millions building a castle-estate in the area, was known to go "prospecting" when funds ran low. Death Valley Scotty would check out for a few days of wandering in the nearby Grapevine Mountains, bringing back suspiciously refined-looking gold that he claimed he had prospected. Many believe that he got his gold from the stacked gold bars in the tunnel system beneath Death Valley.

Evidence of a lost civilisation in Death Valley came in a bizarre report of caves and mummies in the *Hot Citizen*, a Nevada paper, on August 5, 1947. The story ran as follows:

### EXPEDITION REPORTS NINE-FOOT SKELETONS

A band of amateur archaeologists announced today they have discovered a lost civilization of men nine feet tall in Californian caverns. Howard E. Hill, spokesman for the expedition, said the civilization may be "the fabled lost continent of Atlantis".

The caves contain mummies of men and animals and implements of a culture 80,000 years old but "in some respects more advanced than ours," Hill said. He said the 32 caves covered a 180-square-mile area in California's Death Valley and southern Nevada.

### ARCHAEOLOGISTS SKEPTICAL

"This discovery may be more important than the unveiling of King Tut's tomb," he said.

Professional archaeologists were skeptical of Hill's story. Los Angeles County Museum scientists pointed out that dinosaurs and tigers which Hill said lay side by side in the caves appeared on Earth 10,000,000 to 13,000,000 years apart.

Hill said the caves were discovered in 1931 by Dr F. Bruce Russell, Beverly Hills physician, who literally fell in while sinking a shaft for a mining claim.

"He tried for years to interest people in them," Hill said, "but nobody believed him."

Russell and several hobbyists incorporated after the war as Amazing Explorations, Inc. and started digging. Several caverns contained mummified remains of "a race of men eight to nine feet tall," Hill said. "They apparently wore a prehistoric zoot suit—a hair garment of medium length, jacket and knee-length trousers."

### CAVERN TEMPLE FOUND

Another cavern contained their ritual hall with devices and markings similar to the Masonic order, he said.

"A long tunnel from this temple took the party into a room where," Hill said, "well-preserved remains of dinosaurs, saber-toothed tigers, imperial elephants and other extinct beasts were paired off in niches as if on display.

"Some catastrophe apparently drove the people into the caves," he said.

"All of the implements of their civilization were found," he said, "including household utensils and stoves which apparently cooked by radio waves."

"I know," he said, "that you won't believe that."

While of doubtful authenticity, this is an interesting story, to say the least. The last comment about cooking food with radio waves being unbelievable is ironic. That is the

one thing that modern readers of the story could certainly believe was true, considering the widespread use of microwave ovens today. Who had heard of them in 1947?

### Sodom and Gomorrah meet Hiroshima and Nagasaki

Probably the most famous of all ancient "nuke 'em" stories is the well-known biblical tale of Sodom and Gomorrah:

*And the Lord said, Because the cry of Sodom and Gomorrah is great, and because their sin is very grievous... Then the Lord rained upon Sodom and upon Gomorrah, brimstone and fire from the Lord out of heaven; And he overthrew those cities, and all the plain, and all the inhabitants of the cities, and that which grew upon the ground. But his [Lot's] wife looked back from behind him, and she became a pillar of salt... And lo, the smoke of the country went up as the smoke of a furnace. (Genesis 18:20; 19:24-26,28)*

This biblical passage has come to epitomise the destructive power of God's wrath visited on those places which sin. The Bible is very specific about the site of Sodom and Gomorrah plus several other towns; they were in the Vale of Siddim, which was located at the southern end of the Salt Sea (now called the Dead Sea). Other towns in the area, according to the Bible, were Zoar, Admah and Zeboiim (Genesis 14:2). As late as the Middle Ages, a town called Zoar existed in the area.

The Dead Sea is 1,293 feet [394 metres] below sea level and at least 1,200 feet [365 m] deep. The bottom of the sea is therefore about 2,500 feet [762 m] below the level of the Mediterranean. Approximately 25 per cent of the water of the Dead Sea consists of solid ingredients, mostly sodium chloride. Normal ocean water is around 4.6 per cent salt. The Jordan and many smaller rivers empty themselves into this basin, which has no solitary outlet. What its tributaries bring to it in the way of chemical substances remain deposited in the Dead Sea's 500 square miles. Evaporation under the broiling sun takes place on the surface of the sea at a rate of over 230 million cubic feet per day. Arab tradition has it that so many poisonous gases come out of the lake that birds could not fly across it, as they would die before reaching the other side.

The Dead Sea was first explored in modern times in 1848 when W. F. Lynch, an American geologist, led an expedition. He brought ashore from his government research ship two metal boats which he fastened onto large-wheeled carts. Pulled by a long team of horses, his expedition reached the Dead Sea some months later. Lynch and his team discovered that the traditions were correct in that a man could not sink in the sea. They also surveyed the lake, noting its unusual depth and the shallow area or "tongue" at the southern end of the lake. This area is thought to be where the Vale of Siddim was located and the five cities existed. It is possible to see entire forests of trees encrusted with salt beneath the water in this southern part of the lake.

Standard historical theory on the destruction of Sodom and Gomorrah, such as in *The Bible As History* by Werner Keller,<sup>18</sup> holds that the cities of the Vale of Siddim were destroyed when a

plate movement caused the Great Rift Valley—of which the Dead Sea is a part—to shift, and the area at the southern end of the Dead Sea to subside. In the great earthquake there were probably explosions, natural gases issuing forth and brimstone falling like rain. This is likely to have happened about 2000 BC, the time of Abraham and Lot, thinks Keller, though geologists place the event many thousands of years before this. Says Keller:

*The Jordan Valley is only part of a huge fracture in the Earth's crust. The path of this crack has meantime been accurately traced. It begins far north, several hundred miles beyond the borders of Palestine, at the foot of the Taurus mountains in Asia Minor. In the south it runs from the south shore of the Dead Sea through the Wadi el-Arabah to the Gulf of Aqabah and only comes to an end beyond the Red Sea in Africa. At many points in this vast depression, signs of intense volcanic activity are obvious. In the Galilean mountains, in the highlands of Transjordan, on the banks of the Jabbok, a tributary of the Jordan, and on the Gulf of Aqabah are black basalt and lava...*

*The subsidence released volcanic forces that had been lying dormant, deep down along the whole length of the fracture. In the upper valley of the Jordan near Bashan there are still the towering craters of extinct volcanoes; great stretches of lava and deep layers of basalt have been deposited on the limestone surface. From time immemorial the area around this depression has been subject to earthquakes. There is repeated evidence of them and the Bible itself records them...*

Did Sodom and Gomorrah sink when perhaps a part of the base of this huge fissure collapsed still further to the accompaniment of earthquakes and volcanic eruptions?

As for the pillars of salt, Keller says: *To the west of the southern shore and in the direction of the Biblical "Land of the South", the Negeb, stretches a ridge of hills about 150 feet high and 10 miles from north to south. Their slopes*

*sparkle and glitter in the sunshine like diamonds. It is an odd phenomenon of nature. For the most part this little range of hills consists of pure rock salt. The Arabs call it *Jebel Usdum*, an ancient name, which preserves in it the word "Sodom". Many blocks of salt have been worn away by the rain and have crashed downhill. They have odd shapes and some of them stand on end, looking like statues. It is easy to imagine them suddenly seeming to come to life.*

*These strange statues in salt remind us vividly of the Biblical description of Lot's wife who was turned into a pillar of salt... And everything in the neighbourhood of the Salt Sea is even to this day quickly covered with a crust of salt.*

However, Keller himself admits that there is a very serious problem with this theory of a cataclysm sending the Vale of Siddim to the bottom of the Dead Sea: it must have happened many hundreds of thousands, even millions, of years ago—at least

**Did Sodom and Gomorrah sink when perhaps a part of the base of this huge fissure collapsed still further to the accompaniment of earthquakes and volcanic eruptions?**

according to most geologists. Says Keller:

*In particular, we must remember there can be no question that the Jordan fissure was formed before about 4000 BC. Indeed, according to the most recent presentation of the facts, the origin of the fissure dates back to the Oligocene, the third oldest stage of the Tertiary period. We thus have to think in terms not of thousands, but of millions of years. Violent volcanic activity connected with the Jordan fissure has been shown to have occurred since then, but even so we do not get any further than the Pleistocene which came to an end approximately ten thousand years ago. Certainly we do not come anywhere near to the third, still less the second millennium before Christ—the period, that is to say, in which the patriarchs are traditionally placed.*

In short, Keller is saying that any geological catastrophe that would have destroyed Sodom and Gomorrah would have had to have happened a million years ago, or so geologists have told him. Keller says that geologists have not found any evidence of a recent catastrophe at the southern end of the Dead Sea, at least not for about 10,000 years. Says Keller:

*In addition, it is precisely to the south of the Lisan peninsula, where Sodom and Gomorrah are reported to have been annihilated, that the traces of former volcanic activity cease. In short, the proof in this area of a quite recent catastrophe which wiped out towns and was accompanied by violent volcanic activity is not provided by the findings of the geologists.*

So here is the problem: the Dead Sea area may have had a cataclysm that could be the origin of the Old Testament story; however, conservative uniformitarian geologists have said that any such Earth changes must have occurred long before any sort of collective memory of the event.

In late 1999, a new theory was proposed by British Bible scholar Michael Sanders and an international team of researchers who, after several fraught weeks of diving in a mini-submarine, discovered what appears to be the salt-encrusted remains of ancient settlements on the seabed. Sanders told a television crew from BBC/Channel 4 who were making a documentary about the expedition:

*There is a good chance that these mounds are covering up brick structures and are one of the lost cities of the plains,*

*possibly even Sodom or Gomorrah, though I would have to examine the evidence. These Bible stories were handed down by word of mouth from generation to generation before they were written down, and there seems to be a great deal in this one.*

Sanders had unearthed a map dating from 1650, which reinforced his belief that the sites of the two cities could be under the northern basin rather than on the southern edge of the Dead Sea. He recruited Richard Slater, an American geologist and expert in deep-sea diving, to take him to the depths of the Dead Sea in the two-man Delta mini-submarine that was involved in the discovery

of the sunken ocean-liner, the *Lusitania*. Sanders's location for Sodom and Gomorrah, in the deep northern part of the Dead Sea, is even more at odds with history and geology than Keller's theory of the cities being at the shallow southern end.

Therefore we come back to the popular theory that these cities were not destroyed in a geological cataclysm but in a man-made (or extraterrestrial-made) apocalypse that was technological in nature. Were Sodom and Gomorrah attacked with atomic weapons, as Hiroshima and Nagasaki were?

Researcher L. M. Lewis, in his book *Footprints on the Sands of Time*,<sup>19</sup> maintains that both Sodom and Gomorrah were destroyed by atomic weapons and that the salt pillars and high salt content around the Dead Sea are evidence of a nuclear blast. Says Lewis:

*When Hiroshima was being rebuilt, stretches of sandy soil were found to have been atomically changed into a substance resembling a glazed silicon permeated by a saline crystalloid. Little blocks of this were cut from the mass and sold to tourists as souvenirs of the town—and of atomic action.*

*Had an even larger explosion pulverized every stone of every building—and had*

*the complete city disappeared into thin air—there would still have been tell-tale indications of what had occurred on the outskirts of the area of devastation. At some points there would surely be a marked difference in the soil or an atomic change in some object of note.*

Lewis maintains that if the pillars of salt at the end of the Dead Sea were ordinary salt, they would have disappeared with the periodic rains. Instead, these pillars are of a special, harder salt, only created in a nuclear reaction such as an atomic explosion.

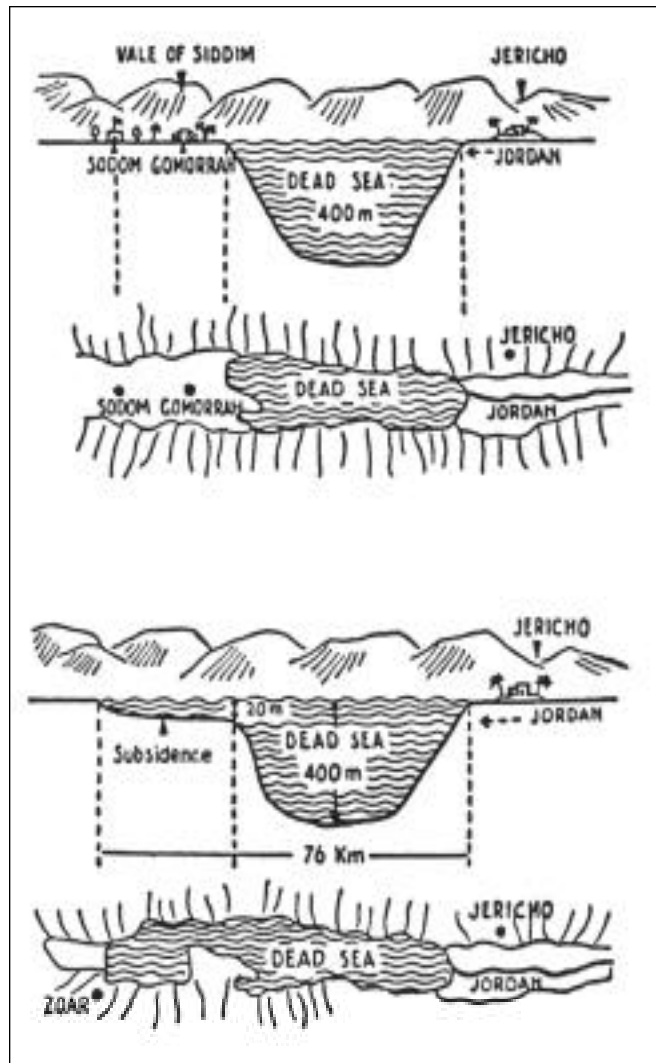

The Dead Sea (a) before subsidence and (b) after subsidence. (Source: Keller, *The Bible As History*)

These pillars of salt have indeed lasted a long time. Not only were they present in ancient times, but are still standing today. Lewis quotes from the historian Josephus, who says in his *History of the Jews*:

*...but Lot's wife, continually turning back to view the city as she went from it, although God had forbidden her so to do, was changed into a pillar of salt; for I have seen it, and it remains to this day.*

Comments Lewis:

*It should be emphasized that Flavius Josephus lived from 37 to approximately 100 AD. As previously stated, Sodom was disintegrated in 1898 BC. How amazing, then, that Josephus should actually have seen the human "pillar of salt" after it had stood for almost 2,000 years! If it had been ordinary salt, it would have disappeared with the first rains.*

There may have been many pillars of salt throughout history, but Lewis thinks the evidence supports an atomic blast:

*The atomic change of the soil upon which Lot's wife stood and that of the shore of Hiroshima have a similarity that cannot be denied! Both had undergone a sudden atomic conversion which could only have been caused by the instant action of nuclear fission. As those things which equal the same thing must be equal to one another, it is difficult to escape the conviction that as Hiroshima was destroyed, so, by similar means, Sodom was disintegrated and Lot's wife at the same moment atomically changed. Relying on the veracity of Josephus, the only conclusion that can be reached is that Sodom was destroyed by nuclear fission.*



The ruins of Parshaspur temple, near Srinagar in Kashmir

The story of Sodom and Gomorrah is puzzling not just because of the destruction but also because of the personalities involved, such as the angel warning Lot to leave the doomed cities. Was Lot warned beforehand that the cities were going to be "nuked" by extraterrestrials or humans with high-tech weapons? Lot was warned to get his family out, but his wife looked back and was blinded by the atomic flash. Perhaps her body was even atomically changed.

At the southern end of the Dead Sea today is a modern chemical plant that looks like an alien base. Strange towers shoot up out of the desert. Bizarre buildings with domes and spires are covered with multi-coloured lights. One expects to see a flying saucer land at any moment. It is the Dead Sea Chemical Works.

During the day it looks like an oil refinery or something similar, but at night the lights that are strung about the facility make it seem otherworldly. This huge chemical plant is said to have an endless supply of valuable minerals, including radioactive salts, with which to work. Are some of these chemicals the result of an ancient atomic blast?

## Was Lot warned beforehand that the cities were going to be "nuked" by extraterrestrials or humans with high-tech weapons?

### Atomic War in Ancient India

These verses are from the *Mahabharata* (written in ancient Dravidian, then later in Sanskrit) and

describe horrific wars fought long before the recorder's lifetime.

- *Various omens appeared among the gods: winds blew, meteors fell in thousands, thunder rolled through a cloudless sky.*
- *There he saw a wheel with a rim as sharp as a razor whirling around the soma... Then taking the soma, he broke the whirling machine...*
- *Drona called Arjuna and said: "Accept from me this irresistible weapon called Brahmasira. But you must promise never to use it against a human foe, for if you did it might destroy the world. If any foe who is not a human attacks you, you may use it against him in battle... None but you deserves the celestial weapon that I gave you."*

This is a curious statement, as what other kind of foe different from a human might there have been? Are we talking about an interplanetary war?

*I shall fight you with a celestial weapon given to me by Drona. He then hurled the blazing weapon...*

- *At last they came to blows, and seizing their maces struck each other...they fell like falling suns.*
- *These huge animals, like mountains struck by Bhima's mace, fell with their heads broken, fell upon the ground like cliffs loosened by thunder.*
- *Bhima took him by the arm and dragged him away to an open place where they began to fight like two elephants mad with rage. The dust they raised resembled the smoke of a forest*



fire; it covered their bodies so that they looked like swaying cliffs wreathed in mist.

• Arjuna and Krishna rode to and fro in their chariots on either side of the forest and drove back the creatures which tried to escape. Thousands of animals were burnt, pools and lakes began to boil... The flames even reached Heaven... Indra without loss of time set out for Khandava and covered the sky with masses of clouds; the rain poured down but it was dried in mid-air by the heat.

Several historical records claim that Indian culture has been around for literally tens of thousands of years. Yet, until 1920, all the "experts" agreed that the origins of the Indian civilisation should be placed within a few hundred years of Alexander the Great's expedition to the subcontinent in 327 BC. However, that was before several great cities like Harappa and Mohenjo-Daro (Mound of the Dead), Kot Diji, Kalibanga and Lothal were discovered and excavated. Lothal, a former port city now miles from the ocean, was discovered in Gujarat, western India, just in the late 20th century.<sup>20</sup> These discoveries have forced archaeologists to push back the dates for the origin of Indian civilisation by thousands of years—in line with what the Indians themselves have insisted all along.

A wonder to modern-day researchers, the cities were highly developed and advanced. The way that each city was laid out in regular blocks, with streets crossing each other at right angles and the entire city laid out in sections, gives archaeologists cause to believe that the cities were conceived as a whole before they were built—a remarkable early example of city planning. Even more remarkable is that the plumbing/sewage systems throughout the large cities were so sophisticated—superior to those found in Pakistan, India and many Asian countries today. Sewers were covered, and most homes had private toilets and running water. Furthermore, the water and sewage systems were kept well separated.<sup>21, 22, 23</sup>

This advanced culture had its own writing, which has never been deciphered. The people used personalised clay seals, much as the Chinese still do today, to officialise documents and letters. Some of the seals found contain figures of animals that are unknown to us today, including an extinct form of the Brahman bull.

Archaeologists really have no idea who the builders were, but their attempts to date the ruins (which they ascribe to the "Indus Valley civilisation", also called "Harappan") have come up with

something like 2500 BC and older, but radiation from the wars apparently fought in the area may have thrown off the date.

The Rama Empire, described in the *Mahabharata* and *Ramayana*, was supposedly contemporaneous with the great cultures of Atlantis and Osiris in the West.

Atlantis, well known from Plato's writings and ancient Egyptian records, apparently existed in the mid-Atlantic and was a highly technological and patriarchal civilisation.

The Osirian civilisation existed in the Mediterranean basin and northern Africa, according to esoteric doctrine and archaeological evidence, and is generally known as pre-dynastic Egypt. It was flooded when Atlantis sank and the Mediterranean began to fill up with water.

The Rama Empire flourished during the same period, according to esoteric tradition, fading out in the millennium after the destruction of the Atlantean continent.

As noted above, the ancient Indian epics describe a series of horrific wars—wars which could have been fought between ancient India and Atlantis, or perhaps a third party in the Gobi region of western China. The *Mahabharata* and the *Drona Parva* speak of the war and of the weapons used: great fireballs that could destroy a whole city; "Kapila's Gance", which could burn 50,000 men to ashes in seconds; and flying spears that could ruin whole "cities full of forts".

The Rama Empire was started by the Nagas (Naacals) who had come into India from Burma and ultimately from "the Motherland to the east"—or so Colonel James Churchward was told. After settling in the Deccan Plateau in northern India, they made their capital in the ancient city of Deccan, where the modern city of Nagpur stands today.

The empire of the Nagas apparently began to extend all over northern India to include the cities of Harappa, Mohenjo-Daro and Kot Diji (now in Pakistan), as well as Lothal, Kalibanga, Mathura and possibly other cities such as Benares, Ayodha and Pataliputra.

These cities were led by "Great Teachers" or "Masters" who were the benevolent aristocracy of the Rama civilisation. Today they are generally called "Priest-Kings" of the Indus Valley civilisation, and a number of statues of these so-called gods have been discovered. In reality, these were apparently men whose mental and psychic powers were of a degree that seems incredible to most people of today. It was at the height of power for both the Rama Empire and Atlantis that the war allegedly broke out, seemingly because of Atlantis's attempt to subjugate Rama.

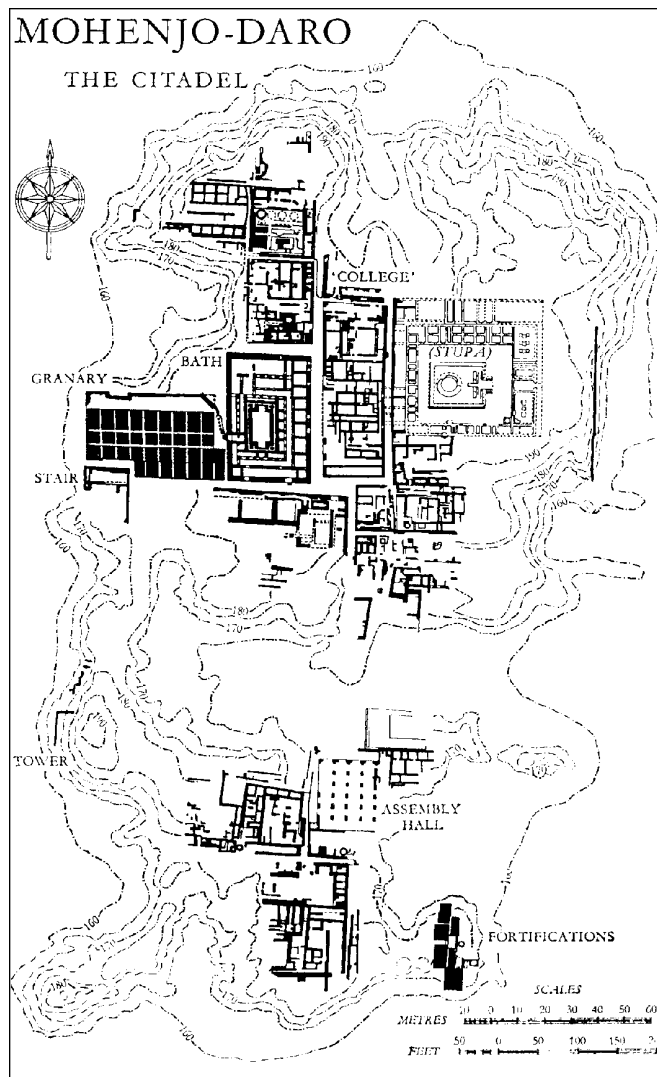

Map of the Citadel at Mohenjo-Daro in the Indus Valley

According to the Lemurian Fellowship lesson materials, the populace surrounding Mu (Lemuria, which predated the other civilisations) eventually split into two opposing factions: those who prized practicality and those who prized spirituality. The citizenry, or educated elite, of Mu itself was balanced equally in these two qualities. The citizenry encouraged the other groups to emigrate to uninhabited lands. Those who prized practicality emigrated to the Poseid Island group (Atlantis), and those who prized spirituality eventually ended up in India. The Atlanteans, a patriarchal civilisation with an extremely materialistic, technologically oriented culture, deemed themselves "Masters of the World" and eventually sent a well-equipped army to India in order to subjugate the Rama Empire and bring it under the suzerainty of Atlantis.

One account of the battle, related by the Lemurian Fellowship, tells how the Rama Empire Priest-Kings defeated the Atlanteans. Equipped with a formidable force and a "fantastic array of weapons", the Atlanteans landed in their *vailixi* outside one of the Rama cities, got their troops in order and sent a message to the ruling Priest-King of the city that he should surrender. The Priest-King sent word back to the Atlantean General:

*We of India have no quarrel with you of Atlantis. We ask only that we be permitted to follow our own way of life.*

Regarding the ruler's mild request as a confession of weakness and expecting an easy victory—as the Rama Empire did not possess the technology of war or the aggressiveness of the Atlanteans—the Atlantean General sent another message:

*We shall not destroy your land with the mighty weapons at our command, provided you pay sufficient tribute and accept the ruler-ship of Atlantis.*

The Priest-King of the city responded humbly again, seeking to avert war:

*We of India do not believe in war and strife, peace being our ideal. Neither would we destroy you or your soldiers who but follow orders. However, if you persist in your determination to attack us*

*without cause and merely for the purpose of conquest, you will leave us no recourse but to destroy you and all of your leaders. Depart, and leave us in peace.*

Arrogantly, the Atlanteans did not believe that the Indians had the power to stop them, certainly not by technical means. At dawn, the Atlantean army began to march on the city. From a high viewpoint, the Priest-King sadly watched the army advance. Then he raised his arms heavenward, and using a particular mental technique he caused the General and then each officer in order of rank to drop dead in his tracks, perhaps of some sort of heart failure. In a panic, and without leaders, the remaining Atlantean force fled to the waiting *vailixi* and retreated in terror to Atlantis. Of the sieged Rama city, not one man was lost.

While this may be nothing but fanciful conjecture, the Indian epics go on to tell the rest of the horrible story, and things do not

turn out well for Rama. Assuming the above story is true, Atlantis was not pleased at the humiliating defeat and therefore used its most powerful and destructive weapon—quite possibly an atomic-type weapon!

Consider these verses from the ancient *Mahabharata*:

*...(it was) a single projectile  
Charged with all the power of the Universe.  
An incandescent column of smoke and flame  
As bright as the thousand suns  
Rose in all its splendour...*

*...it was an unknown weapon,  
An iron thunderbolt,  
A gigantic messenger of death,  
Which reduced to ashes  
The entire race of the Vrishnis and the Andhakas.*

*...The corpses were so burned  
As to be unrecognisable.  
The hair and nails fell out;  
Pottery broke without apparent  
cause,  
And the birds turned white.*

*After a few hours  
All foodstuffs were infected...  
...to escape from this fire  
The soldiers threw themselves in  
streams  
To wash themselves and their  
equipment.<sup>24</sup>*

In the way we traditionally view ancient history, it seems absolutely incredible that there was an atomic war approximately 10,000 years ago. And yet, of what else could the *Mahabharata* be speaking? Perhaps this is just a poetic way to describe cavemen clubbing each other to death; after all, that is what we are told the ancient past was like. Until the bombing of Hiroshima and Nagasaki, modern mankind could not imagine any weapon as horrible and devastating as those described in the ancient Indian

texts. Yet they very accurately described the effects of an atomic explosion. Radioactive poisoning will make hair and nails fall out. Immersing oneself in water gives some respite, though is not a cure.

Interestingly, Manhattan Project chief scientist Dr J. Robert Oppenheimer was known to be familiar with ancient Sanskrit literature. In an interview conducted after he watched the first atomic test, he quoted from the *Bhagavad Gita*:

*'Now I am become Death, the Destroyer of Worlds.'*  
*I suppose we all felt that way.*

When asked in an interview at Rochester University seven years after the Alamogordo nuclear test whether that was the first atomic bomb ever to be detonated, his reply was:

*Well, yes, in modern history.<sup>25</sup>*

**In the way we  
traditionally view  
ancient history,  
it seems absolutely  
incredible that there  
was an atomic war  
approximately  
10,000 years ago.  
And yet, of what else  
could the *Mahabharata*  
be speaking?**

Continued on page 83





# — *FORMATIVE FIELDS* —

## UK CROP CIRCLES OF 2000

*This year's bountiful yield of crop glyphs featured circular, triangular, diamond-shaped and grid-like patterns as well as some unusual optical effects.*

In 1990, the crop circle mystery burst into the international media with a flurry of utterly extraordinary patterns etched into the fields. Until then, the phenomenon had been just another quaint, Fortean eccentricity; but these new arrivals leapt from the formerly simple circles and rings into an inexplicable evolution of complex designs which would blossom and develop over the next 10 years.

As the century turned and another decade began, expectations were high that the phenomenon would take another quantum leap. It didn't quite happen like that, but the continuing progress of its serene, upward curve ensured that the marvels of the 2000 crop circle season were no disappointment.

Things took a while to get going, with just a handful of formations gracing the fields between April and June, but of these, on 20 May, Alton Barnes—the classic circle-site of old—yielded up a sign of things to come with a pentagonal design which played 3D tricks with the eyes.

The era of optical-illusion crop formations had dawned and would be followed up with some truly mesmerising patterns later in the summer. A chequerboard grid of rectangles at Windmill Hill on 18 June gave the startling effect of simultaneously appearing as a sphere. A "Chinese puzzle" emblem, which arrived at Bishops Cannings on the same night, resembled three pentagrams seen in perspective, clinging to the surface of another sphere.

The incorporation of triangles in crop designs also became commonplace. One such example arrived next to the West Kennett longbarrow near Avebury on 2 June. Initially unimpressive with a very messy lay, the triangular outline which appeared there, ringed with 12 flattened smaller triangles, suddenly surprised everyone on 3 June by transforming itself overnight into an exquisite emblem of standing and flattened areas, the formerly haphazard lay miraculously combed into good order!

In fact, the whole Kennett/Silbury Hill area was very much the major hotbed of circular activity this year, with virtually every other field in a square mile being visited by a formation. Mystics say this was due to a cylindrical shaft suddenly and unexpectedly opening up in the top of the ancient and mysterious Silbury Hill itself. Though this was almost certainly due, in part at least, to the shoddy workmanship over 200 years ago of treasure-hunting excavators who didn't fill in their diggings properly and simply plugged the top, many felt that potent forces were released when the plug finally collapsed inwards. Strange lights were seen over the Hill in the weeks preceding the hole's arrival. Whatever the real circumstances (however mundane) behind the subsidence, those who believe Silbury to be an accumulator of "Earth energy" hold that its unexpected opening must have led to a significant release of the focused natural power that fires up this sacred landscape.

Of the formations which appeared in this hotspot, the most shattering was a grid, like a circuit board, comprising 1,600 rectangular components, which appeared at East Kennett on 2 July. The geometrical logic of how one would go about creating such a pattern—with merging sections of standing squares becoming flattened squares—troubled even the best crop circle geometers. On the ground, one could not make head nor tail of how the design worked, nor of how any human could possibly have attempted it.

This formation, with its unique qualities, actually grabbed the attention of the newspapers; but the media, except for publishing one or two more positive pieces, soon slipped back into the easy scepticism which circle enthusiasts have come to expect, with a variety of hoax-promoting articles and letters. Several man-made circles were allegedly filmed in the making, the plan being for the footage to be broadcast later on television—to the

Introduction  
by Andy Thomas © 2000

Southern Circular Research  
13 Downsview Cottages  
Cooksbridge, East Sussex BN8 4TA, UK  
E-mail: SCR@landl.freeserve.co.uk

Images from  
Crop Circle Connector website:  
[www.cropcircleconnector.com](http://www.cropcircleconnector.com)

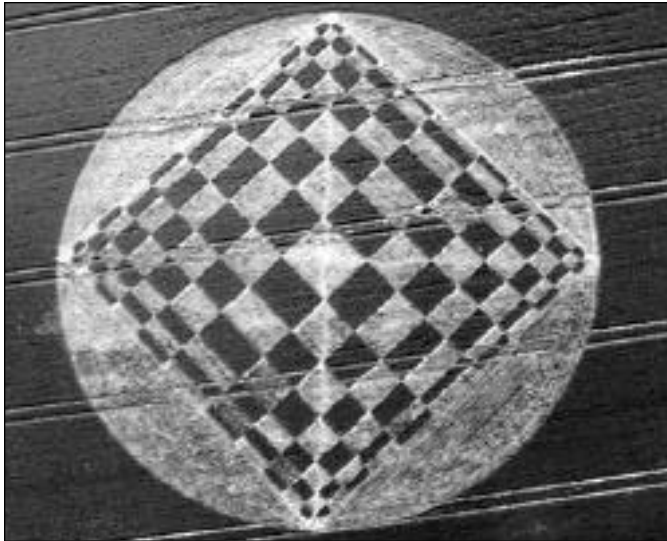

Windmill Hill, near Avebury, Wiltshire. Reported 18th June.  
(Image © Francine Blake/Wiltshire Crop Circle Study Group 2000)

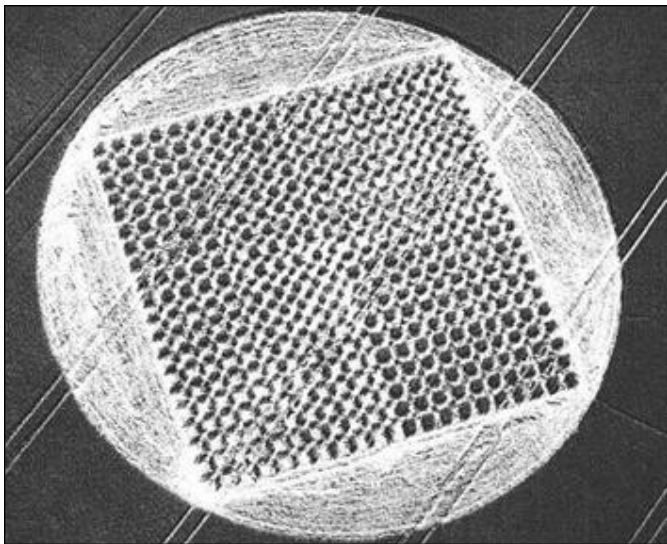

East Kennett, near Avebury, Wiltshire. Reported 2nd July.  
(Image © Steve Alexander 2000)

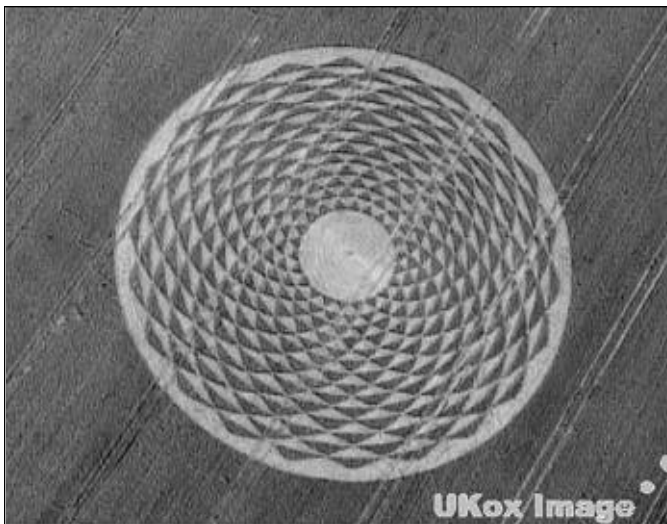

Woodborough Hill, near Alton Priors, Wiltshire. Reported 13th August.  
(Image © Steve Alexander 2000)

resigned yawns of researchers who have seen and survived all this before.

The pronouncement by veteran circle researcher Colin Andrews—that he now believes the formations are man-made in 80% of cases, the rest being caused by natural magnetism—achieved much publicity for the phenomenon but was met with cynicism and indifference by some sceptics and believers alike. As no official paper has yet been produced for scrutiny, this latest assertion remains just another theory until the necessary evidence is put forward.

The notion that people are responsible for creating such a large proportion of formations has been severely challenged by many researchers who point to a lot of details which suggest otherwise. However, the notion that human hoaxers are responsible for at least a certain *quota* of crop glyphs seems now to have been widely absorbed by the crop circle community without too much harm—some considering that, for good or for ill, what man-made formations there are simply add to the overall mystery and interact with the landscape in their own way. Many formations, though, continue to defy the idea that humans could create such complexity and beauty without error in conditions of darkness.

The generally accepted masterpiece of the year was certainly the breathtakingly fantastic pattern which arrived at Avebury Trusloe on 22 July. A staggering series of standing and flattened diamonds, splayed outwards in a containing circle, gave the impression (perhaps ironically, given the Andrews pronouncement) of particles held in magnetic fields. Despite the inevitable distracting claims of authorship, made by the usual egocentric "artists" in one newspaper—as ever, without a scrap of evidence to support them—even seasoned researchers were open-mouthed in awe at this show-stopper. But the show didn't stop there, for another astonishing pattern demonstrating similar mathematical principles appeared at Woodborough Hill on 13 August.

Perhaps the event that best illustrated just how far the phenomenon has come in the last 10 years was the very unusual formation which occurred at Everleigh Ashes on 19 July. In 1989, the cereal world had got a tiny taste of the developments which would rock it to its young foundations the following year, when the last formation of that season, at Winterbourne Stoke, was found to be a circle split into four quarters of linear crop lay instead of a conventional swirl. The Everleigh Ashes formation of 2000 saw four such quartered circles aligned as a Celtic cross orbiting a round barrow, which made up the central component of the pattern. On the antique mound itself, the grass had been

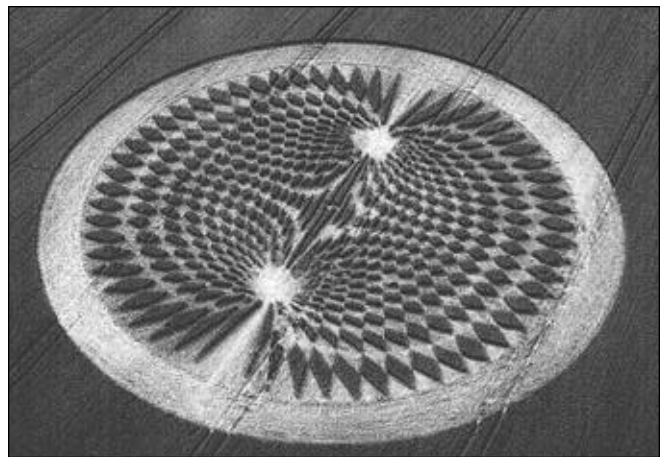

Avebury Trusloe, near Avebury, Wiltshire. Reported 22 July.  
(Image © Steve Alexander 2000)

swirled to complete the effect. How things have moved on!

The photographs which accompany this article speak for the many beautiful crop formations which arrived this year. But not all of this year's efforts were confined within the borders of Wiltshire; other counties, including Hampshire, Kent, Leicestershire, Yorkshire, Sussex and others besides, all played their part in the continuing development, as did the many other countries which now regularly receive their own gifts each year.

We have learnt much over the last decade—but not the answer to the continuing mystery. That still eludes, whether the solution be extraterrestrial, geophysical, psychic or spiritual. But the devotees seeking widely accepted credibility for this unique enigma have a passion that has not diminished, despite all the cutting scepticism and problems encountered.

This year, the three-day international Glastonbury Symposium celebrated its 10th anniversary with a radiant event which I was privileged to be a part of, as people from around the world came together to reaffirm their enthusiasm for these amazing patterns, associated issues and the widening mindsets they engender. Throughout the summer, other events took place which brought like-minded individuals together. Each year, numbers at the best of these events swell, not diminish. There are many who see beyond the scepticism and hype.

In a recent Internet article, the BBC Online science correspondent Dr David Whitehouse described anyone who believed that crop circles were not made by people as "misguided, a fool or a charlatan". Clearly, there are many prepared to risk being perceived as all of these in their pursuit of the truth.

#### **About the Author:**

Andy Thomas is editor of the bimonthly crop circle journal *SC*, a founder member of the Southern Circular Research team, and author of three books exploring aspects of the circles: *Fields Of Mystery*, *Quest For Contact* (with Paul Bura), and *Vital Signs*.

For more information and images, please contact :

• **Crop Circle Connector Website:**  
[www.cropcircleconnector.com](http://www.cropcircleconnector.com)

• **Steve Alexander**  
27 St Francis Road, Gosport, Hants PO12 2UG, UK  
Tel/Fax: +44 (0)2392 352867  
E-mail: [temporarytemples@netscapeonline.co.uk](mailto:temporarytemples@netscapeonline.co.uk)

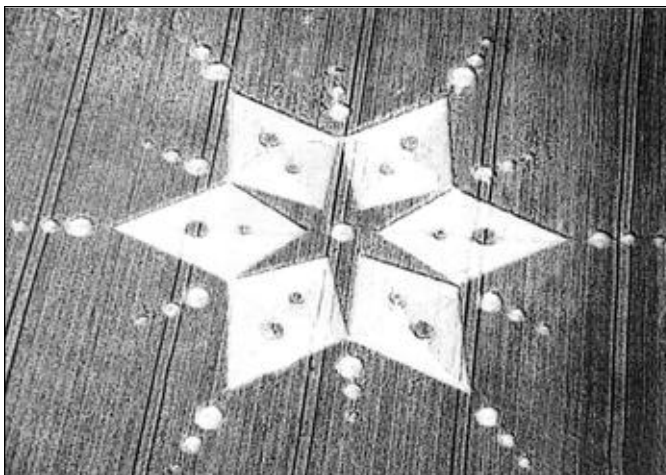

Istead Rise, near Gravesend, Kent. Reported 29th July.  
(Image © Andrew King 2000)

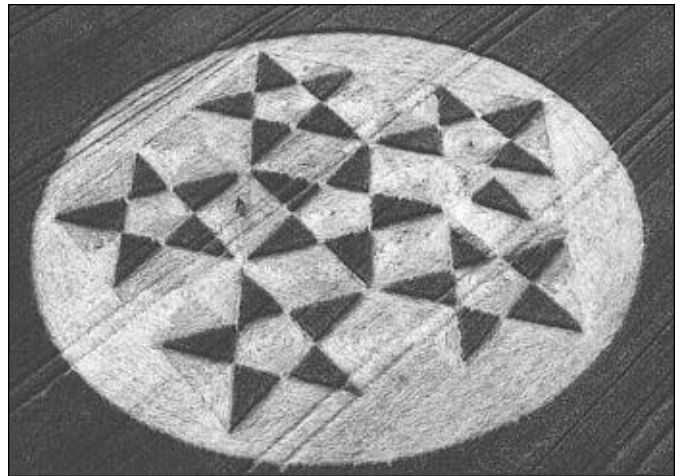

Silbury Hill, near Avebury, Wiltshire. Reported 25th July.  
(Image © Steve Alexander 2000)

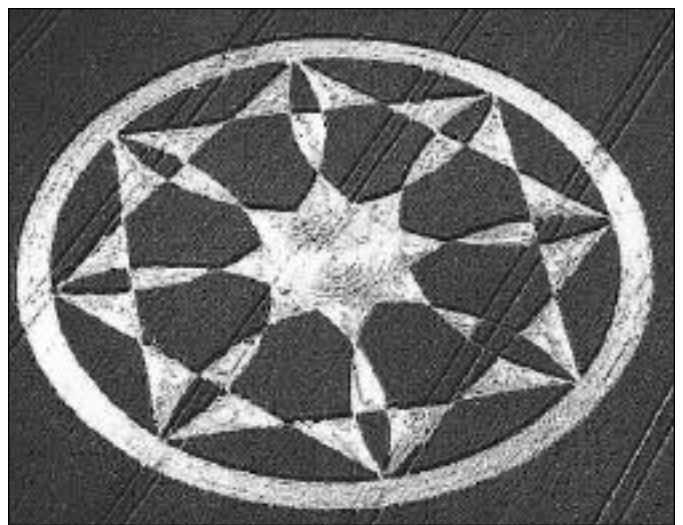

Bishop Cannings, near Devizes, Wiltshire. Reported 27th June.  
(Image © Steve Alexander 2000)

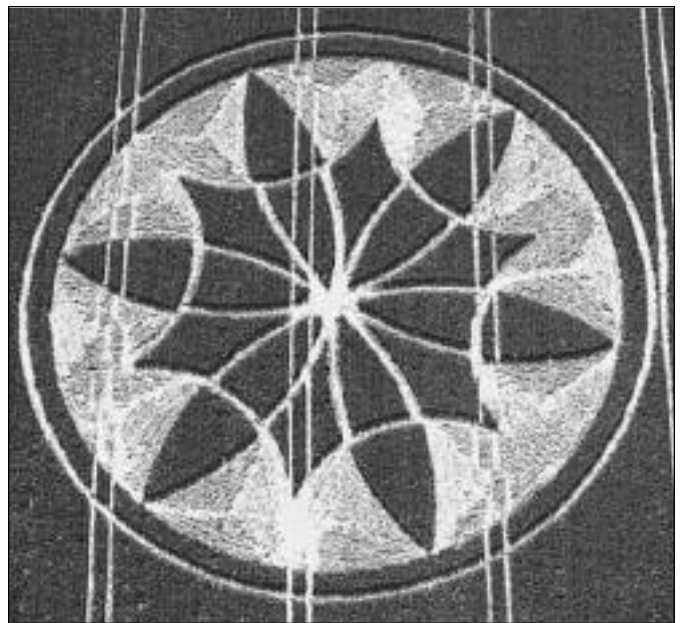

Under Milk Hill, near Alton Barnes, Wiltshire. Reported 1st July.  
(Image © Steve Alexander 2000)



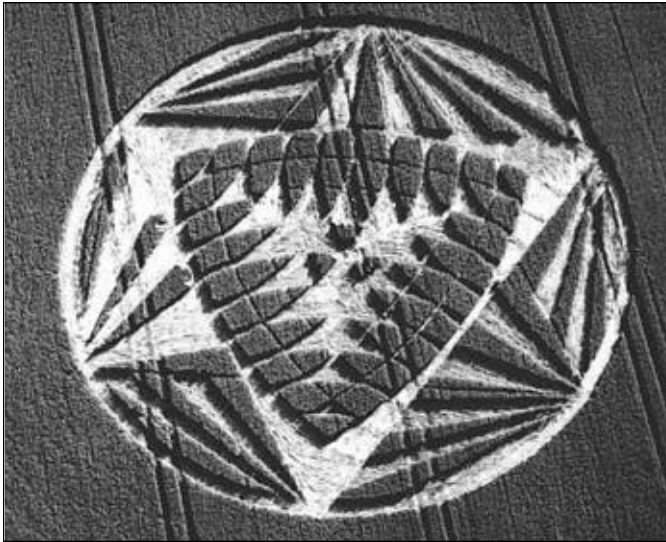

Allington Down, near Devizes, Wiltshire. Reported 1st August.  
 (Image © Steve Alexander 2000)

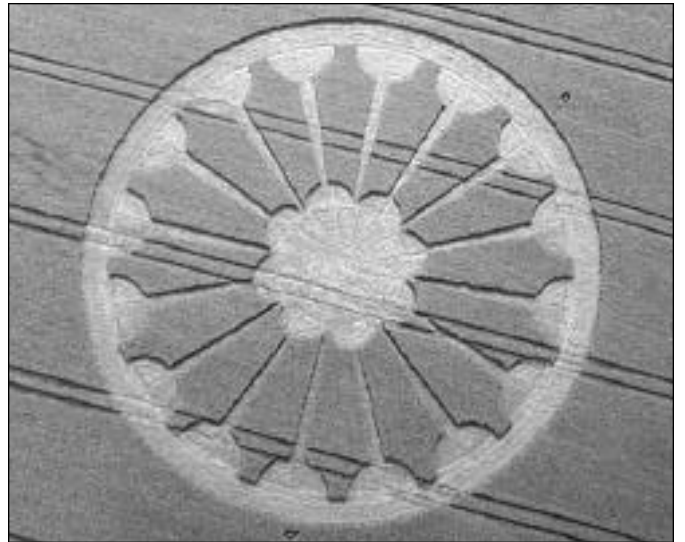

South Field, Alton Priors, Wiltshire. Reported 19th June.  
 (Image © Francine Blake/Wiltshire Crop Circle Study Group 2000)

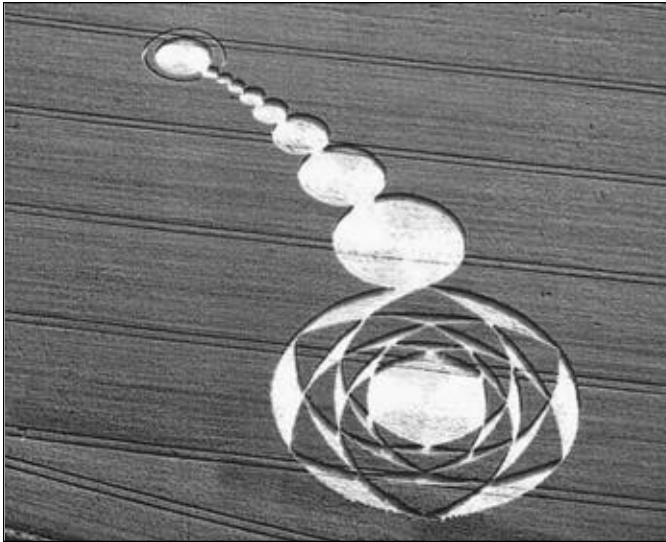

Uffington White Horse, near Woolstone, Oxfordshire. Reported 22nd July.  
 (Image © Steve Alexander 2000)

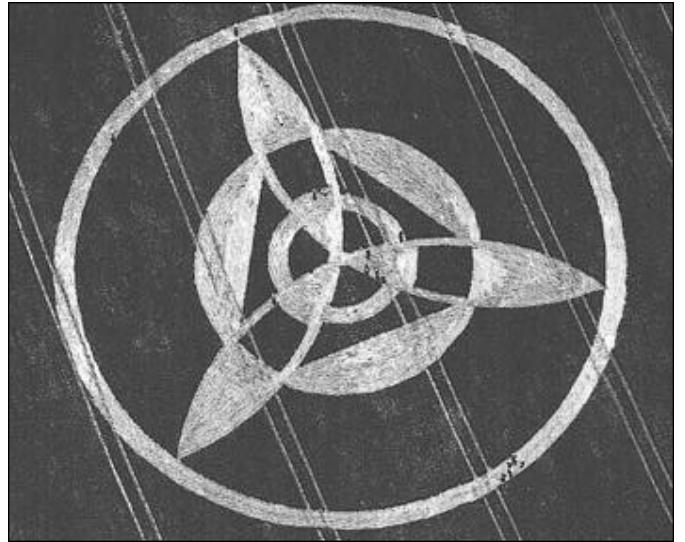

White Hill, near Lockeridge Dene, Wiltshire. Reported 19th July.  
 (Image © Steve Alexander 2000)

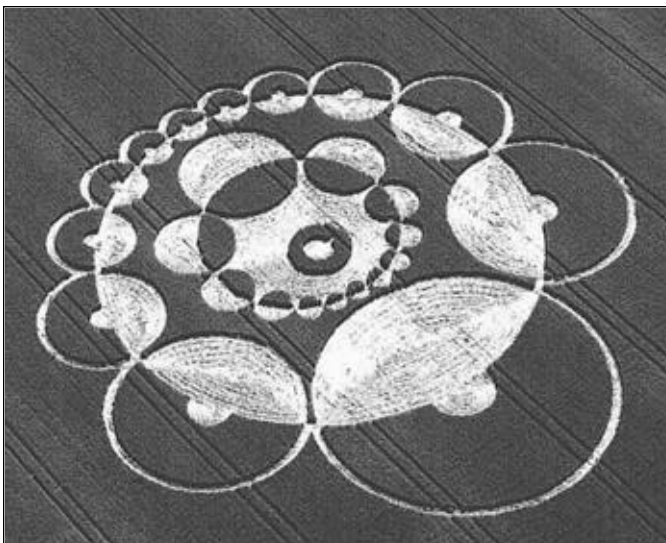

Bishop's Sutton, near Winchester, Hampshire. Reported 15th July.  
 (Image © Steve Alexander 2000)

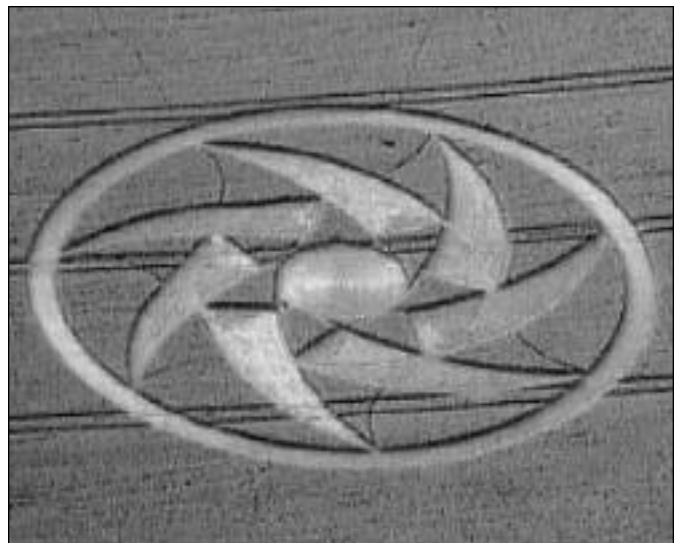

Broadbury Banks, near Wilsford, Wiltshire. Reported 5th August.  
 (Image © Steve Alexander 2000)









## FATIMAGATE!

Has the Third Secret of Fátima been revealed or covered up?

by John Hogue © 2000

On 26 May 2000, the Vatican finally released the long-awaited Third Secret of Fátima.

Fifty-six years earlier, Sister Lucia de Jesus dos Santos (custodian of this prophecy) claimed that an apparition of the Virgin Mary had given her a specific date for the revelation of this Secret. She said that the Pope must permit its dissemination to the world "no later than 1960". Forty years later, the Vatican's chief theologian, Cardinal Joseph Ratzinger, finally presented the document at a press conference on 26 May. This is how it reads:

### The Prophecy of the Third Secret

"I write in obedience to you, my God, who commands me to do so through his Excellency the Bishop of Leiria and through your most Holy Mother and mine.

"After the two parts which I have already explained, at the left of Our Lady and a little above we saw an angel with a flaming sword in his left hand. Flashing, it gave out flames that looked as though they would set the world on fire. But they died out in contact with the splendour that Our Lady radiated towards him from her right hand. Pointing to the earth with his right

hand, the angel cried out in a loud voice, 'Penance, penance, penance!'

"And we saw in an immense light that is God—something similar to how people appear in a mirror when they pass in front of it—a bishop dressed in white. We had the impression that it was the Holy Father.

"Other bishops, priests, religious men and women were going up a steep mountain, at the top of which there was a big cross of rough-hewn trunks as of a cork-tree with the bark.

"Before reaching there, the Holy Father passed through a big city half in ruins, and half-trembling with halting step, afflicted with pain and sorrow, he prayed for the souls of the corpses he met on his way.

"Having reached the top of the mountain, on his knees at the foot of the big cross he was killed by a group of soldiers who fired bullets and arrows at him; and in the same way, there died one after another the bishops, priests, religious men and women, and various lay people of different ranks and positions.

"Beneath the two arms of the cross there were two angels, each with a crystal aspersorium in his hand, in which they gathered up the blood of the martyrs and with it sprinkled the souls that were making their way to God."

(End of prophecy)

The prophecy and Cardinal Ratzinger's interpretation have stunned and upset many Catholics and prophecy-watchers around the world. The Cardinal, who heads the papal cabinet, the Office for the Doctrine of the Faith (better known in history as the Office of the Grand Inquisitor), declared that the Third Secret only referred to events which have already happened.

"A careful reading of the text will probably prove disappointing or surprising after all the speculation it has stirred," said Cardinal Ratzinger at the press conference. "No great mystery is revealed; nor is the future unveiled," he added.

The good Cardinal thinks the assassination of a Pope and a multitude of Catholic bishops, priests and laity on a mountaintop before a half-ruined city fulfills a specific past event. He would have the world believe that the prophecy describes the assassination attempt on Pope John Paul II by Mehmet Ali Agca in 1981.

Many believe they have experienced nothing less than a "white cassock wash" of one of Catholicism's most anticipated prophetic messages.

In all my 30 years as a scholar of prophetic traditions, I have seen some interpretive stretches—but Cardinal Ratzinger's spin on this prophecy is as weak as they come. Indeed, I have seen more imaginative twists of reason made by

## THE TWILIGHT ZONE

the *National Enquirer*. I would not even pin 10 per cent of the Third Secret he presented as a fulfilled prophecy.

Many of the facts about that event just do not match the prophecy. Agca's bullets wounded the Pope and two bystanders. No-one died, and no bishops, priests and laity were martyred as the prophecy demanded. As far as I know, Rome stood undamaged in 1981, and the scene of the assassination was not on top of a mountain but on the flat plain of the Vatican plaza.

Beyond the interpretation of the Third Secret, there are a number of factual inconsistencies in Cardinal Ratzinger's past and current statements about it. It is a well-known fact among Fátima prophecy-watchers that the first line of the Third Secret revealed on 26 May is not the line proclaimed decades ago by Sister Lucia.

A number of those who have seen the prophecy (among them the late Father Malachi Martin) describe a vision diametrically different in content than that presented on 26 May. Even the Third Secret's physical pages, offered as evidence at the news conference, are suspect. Up to 26 May, Cardinal Ratzinger officially agreed with other witnesses that Sister Lucia wrote the prophecy in 24 lines on a single page. Now Ratzinger presents a four-page, handwritten document of 62 lines!

These and many other inconsistencies and prophetic stretches only add support to a growing belief that the highest echelons of the Vatican are involved in a cover-up.

(Source: John Hogue, author of *"Messiahs: The Visions and Prophecies for the Second Coming"*, *"The Last Pope: The Decline and Fall of the Church of Rome"*, and *"Nostradamus: The Complete Prophecies"*, website [www.hogueprophecy.com](http://www.hogueprophecy.com))

### ANCIENT TEMPLE DISCOVERED BENEATH LAKE TITICACA

A stone anchor and animal bones are among the artefacts scientists say they have found beneath Lake Titicaca in the Andes, in what they claim is a giant temple over 1,000 years old.

After 18 days of diving below the clear waters of Titicaca, scientists said on Tuesday, 22 August, that they had discovered a temple, a crop terrace, a pre-Incan road, a containing wall and a number of ceramic artefacts on the lake's floor.

"We've found what appears to have been a 200-metre-long, 50-metre-wide holy temple, a terrace for crops, a pre-Incan road and an 800-metre-long containing wall," said Lorenzo Epis, the Italian leader of the Atahualpa 2000 expedition.

While a submerged city has not been found, Mr Epis said that the ruins appeared to be 1,000 to 1,500 years old. They thus predate the Incas and could point to the Tiahuanaco people who lived on Titicaca's shores before becoming part of the Inca Empire.

Lake Titicaca, some 12,464 feet (3,800 metres) above sea level, lies on the border between Bolivia and Peru and is the highest

navigable lake in the world. It has long been the subject of legends about a lost underwater city, but there has been little research because of the logistical difficulties of diving at altitude.

"I strongly support the hypothesis that what was found by the Atahualpa 2000 expedition are the ruins of a submerged pre-Columbian temple," said Eduardo Pareja, a Bolivian scientist who was

among those who explored the site, around 90 miles northeast of Bolivia's capital, La Paz.

The Atahualpa 2000 expedition—backed by the international scientific group Akakor Geographical Exploring, and funded by ENTEL, a Bolivian telecommunication company owned by the Italian corporation STET—first made a trip to Titicaca in 1998 to look at underwater caves and to research diving techniques at high altitude.

Marco Antonio Simi, who was on that expedition, said that the groundwork on pressure levels allowed the group to return this year. Most diving technology is based on ocean-bound dives, where pressure levels are very different.

The team was looking for an underwater temple.

"What they found was the beginning of what they were looking for," Simi said.

The team made more than 200 dives into water as deep as 65 to 100 feet (20 to 30.5 metres) and recorded their finds on film.

The expedition is to publish its full findings in November and has plans to raise more archaeological remains to the surface. (Source: *The Guardian, UK, 24 August 2000*)

### SYRIAN RUINS REVISE BIRTH OF URBAN CULTURE

A joint Syrian-American excavation team has uncovered the ruins of a city dating back to around 4000 to 3700 BC, which suggest that the rise of urban civilisation occurred earlier than previously thought—and before the invention of writing.

Archaeologists from the excavation team found a protective city wall under a huge mound in a region of northeastern Syria known as Tell Hamoukar.

Until the discovery last year, archaeologists claimed that the only cities dating back to 4000 BC were in Sumeria, between the Tigris and Euphrates rivers, in an area that is now Iraq.

The discovery at Tell Hamoukar suggests that ideas behind cities may have predated the Sumerians, according to McGuire Gibson of the University of Chicago's Oriental Institute, the joint partner in the excavation.

"We need to reconsider our ideas about the beginnings of civilisation, pushing the time further back," said Gibson.

Tell Hamoukar is located between the legendary Tigris and Euphrates rivers in what is Syria today. In the earliest period

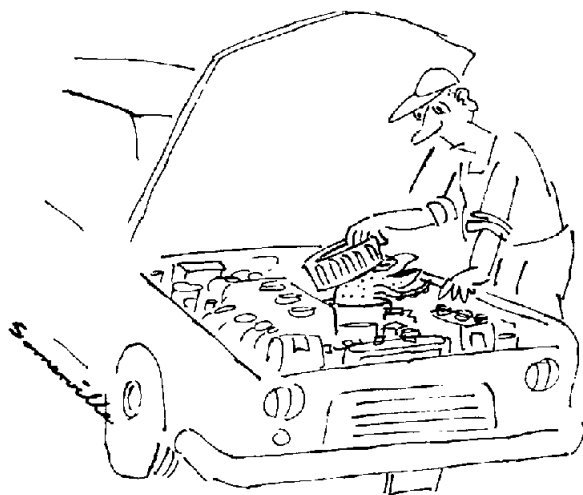

"Hello, I am Zyrxxx. I am one of an extraterrestrial race that travels from planet to planet invading and taking over carburetors."

of occupation, from 4000 to 3700 BC, it was spread out over at least 500 acres, making it comparable in size to some of the largest ancient cities in the Middle East, though Gibson said "the entire 500 acres were probably not inhabited at any one time".

During the second habitation phase around 3700 to 3500 BC—still before any evidence of Uruk colonists or the introduction of writing—it was a well-organised, prosperous town of about 30 acres, apparently enclosed by a defensive wall 10 feet high by 13 feet wide. There is evidence of food preparation on an institutional scale, with large ovens and cooking pots. It's believed the population may have reached 25,000 there in the Mesopotamian period.

Dr Mouhammed Maktash, director of the Syrian-American joint excavation, commented: "There is no question this is the most exciting find I have come across. Of course you can find older individual pieces [artefacts], but there is a big difference between a small village and a city."

Dr Maktash, who is director of antiquities at the regional museum at Raqqa, told the London *Independent* newspaper that one of the most astonishing finds was of living quarters, double-walled "to encourage air flow, suggesting the inhabitants had designed their own air-conditioning system to combat summer temperatures of more than 40 degrees Centigrade".

The excavation team has also unearthed stone god icons and other artefacts, such as porcelain figurines of lions, leopards, bears and horses, together with pottery and 7,000 beads, suggestive of an advanced culture.

"From the beginning, we knew that Hamoukar was very old; but when we excavated, we found things we have never seen before," said Dr Maktash.

Surface indications and excavations show that the area was occupied at various times, and include more recent Hellenistic and early Islamic material.

The discoveries will prompt a reassessment

of how mankind developed in the "cradle of civilisation" between the two great Middle Eastern rivers. Historians have theorised that the Sumerians established the oldest known "modern" civilisation in about 3500 BC.

According to Maktash, "...we don't know who the people were who lived at Hamoukar. If they were here first, the big question is: where did the Sumerian civilisation come from—from nothing? It's possible they came from Hamoukar. This will change many things in our understanding of history."

(Sources: *Associated Press*, 23 May 2000; *Independent*, 3 July 2000; University of Chicago Chronicle, 25 May 2000, website <http://chronicle.uchicago.edu/000525/civilization.shtml>)

## GEOMAGNETIC DATA CONFIRMS EARLIER "OUT OF AFRICA" MIGRATION

Using geological clues from an ancient shift in the Earth's magnetic field, scientists working in Israel have significantly pushed back the date of an "out of Africa" migration of early humans that brought new technologies to Eurasia in the midst of the early Ice Age.

Their findings also indicate that our ancestors' tool-making skills were more sophisticated for that time than previously believed.

A team, working at the archaeologically rich site of Gesher Benot Ya'aqov (GBY) in the Dead Sea rift of northern Israel,

found that early humans belonging to the species *Homo erectus* traversed the corridor between Africa and Eurasia 780,000 years ago, bringing with them new technologies.

According to co-author Craig Feibel, a geologist and assistant professor of anthropology and geology at Rutgers University, the findings indicate this migration occurred some 250,000 years earlier than had been suspected.

They also confirm that the site's abundant trove of stone tools, including hand-axes and cleavers, reflects a higher level of skill and sophistication than scientists thought existed at that time.

Feibel, who was one of two geologists on the team, reconstructed the geological sequence from sediments at GBY. The sediments showed clear evidence dating them to the most recent reversal in the Earth's magnetic field 780,000 years ago.

"Until this recent work, we didn't have a clear age-estimate. Scientists had estimated the technology and associated flora and fauna at a half-million years, but that was conservative," Feibel said. "This time we were fortunate to find in the sediments a record of the shift in the Earth's magnetic field, which is a well-dated phenomenon."

Feibel noted the discovery was a serendipitous one that solved a longstanding mystery regarding the site's true age.

(Sources: *Science*, vol. 289, no. 5481, 11 August 2000; *ABC News*, [www.abcnews.go.com/sections/science/DailyNews/hominid-000811.html](http://www.abcnews.go.com/sections/science/DailyNews/hominid-000811.html))







# REVIEWS

## BOOKS

Reviewed by Ruth Parnell

### PHYSICIAN: Medicine and the Unsuspected Battle for Health Freedom

by Richard Leviton

Publisher: Hampton Roads, USA, 2000  
ISBN: 1-57174-168-2 (579pp tpb)  
Price: A\$41.00; NZ\$52.95; £12.99;  
NLGfn/a; US\$16.95

Available: **Australia**—Gemcraft, tel (03) 9888 0111; **NZ**—NEXUS Office, tel (09) 405 1963; **UK**—Airlift Book Co., tel 020 8804 0400; **Europe**—NEXUS office, tel +31 321 380558; **USA**—Hampton Roads, tel (804) 296 2772, www.hrpub.com

Since classical Greek times there has been a struggle between two approaches to practising medicine—the allopathic and the empiric, or alternative—and the struggle is reaching a climax today, particularly in the US, says Richard Leviton in *Physician*.

In this powerful thesis, he restakes the territory where modern medicine must tread in the 21st century. He restates the profound metaphysical principles that are at the basis of human freedom, and contrasts them with facts about the politics and policies of the modern medical system.

His key argument is that orthodox medicine generally operates in a way that is contrary to spiritual unfoldment and, as it stands now, is "a prime obstacle to healthy human soul life". He sees the main political issue as being the suppression of true freedom of choice in the medical marketplace, where both allopathic and alternative practices can operate—and be chosen—on an equal basis.

Leviton, an author and journalist, is a

former editor of *Alternative Medicine* magazine. Here he explores the link between human health and ecology...consciousness... and how each form of medicine deals with or ignores this fundamental relationship. Drawing at times on the anthroposophy of Rudolf Steiner, he probes the spiritual layers of illness and posits that supervaccines may be the ultimate soul-destroyers that Steiner foresaw. What Leviton is saying is that our mindsets need to undergo a major paradigm shift—one that the orthodoxy is not yet ready to confront...but sooner or later must.

### DOGS THAT KNOW WHEN THEIR OWNERS ARE COMING HOME...And Other Unexplained Powers of Animals by Rupert Sheldrake

Publisher: Arrow, UK, 2000 (first published by Hutchinson, UK, 1999)

ISBN: 0-09-925587-1 (300pp pb)

Price: A\$21.90; NZ\$27.95; £7.99

Available: **Aust/NZ/UK**—Random House

Millions of people can attest to their pets having powers of perception which go beyond the known senses. British biologist Dr Rupert Sheldrake, famous for his morphic resonance theory of causative formation, devoted five years to investigating this phenomenon which has been so neglected by the scientific orthodoxy partly because of a taboo against taking pets seriously.

For too long, Dr Sheldrake points out, the wealth of experience among people who deal with domestic and domesticated animals has been dismissed as anecdotal—so he set about documenting this evidence, sometimes using video cameras to facilitate data collection objectively.

*Dogs That Know When Their Owners Are Coming Home* is not just about dogs, but

cats, cows, horses, parrots and monkeys that demonstrate abilities we would classify as "paranormal" or "psychic". However hard to quantify, Dr Sheldrake's findings show that many animals that have a bond with their "owners" *do* know in advance when they are coming home, even if these returns are irregular or in different vehicles; and that some animals anticipate these returns at the moment when their humans expressed to themselves the *intent* to go home.

Sheldrake presents evidence for animal empathy, such as in comforting, healing and responding to distant deaths and accidents; telepathic calls and commands; directional sensing capability that defies explanation; and ability to pre-sense anything from fits in epileptic owners to earthquakes. He suggests that these phenomena might be explicable in terms of morphic fields, the bond between human and animal being like an elastic band when the two are separated. A fascinating theory which has as many implications for understanding ourselves as well.



# REVIEWS



## BOOKS

### THE DIVINE DECEPTION: The Church, the Shroud and the Creation of a Holy Fraud by Keith Laidler

Publisher: Headline, UK, 2000  
ISBN: 0-7472-7484-3 (312pp hc);  
0-7472-7485-1 (tpb)

Price: A\$32.83 (tpb); NZ\$39.95; £18.99  
Available: **Aust/UK**—Hodder Headline;  
**NZ**—NEXUS office, tel (09) 405 1963

The Shroud of Turin is a mediaeval fraud concealing a religious truth, says Keith Laidler, PhD, in *The Divine Deception*, the follow-up to his 1998 book, *The Head of God*. And it was a fraud perpetrated by the Knights Templars who learned the *camera obscura* technique of recording images from the Arab alchemists—a technique that Dr Laidler believes can account for the image on the Shroud. But whose image?

Utilising anthropometric and computer-aided analysis, Dr Laidler has come to the stunning conclusion that the image is a composite: the torso and proportionately smaller head belonged to two different people. As if this hasn't been staring us in the face all along! The image of the head is that of a real, embalmed head—but if not the head of Jesus, allegedly excavated from the Temple of Solomon in Jerusalem by the Knights Templars at their inception, then whose is it?

The Nazirites, with whom Jesus is associated, were heirs to the sacred cult of the head or skull, one that can be traced to Cayonu in the Near East circa 7000 BC (and is evident in many parts of the ancient world). And the Templars are known to

have paid homage to the Father of Wisdom, Baphomet, represented as a head. Were they inheritors of the oracular head cult?

Dr Laidler believes they were, and that they went to obsessive lengths to protect their treasure, yet recording its image for posterity. In the mediaeval world where relic worship was big business, the Templars shielded a relic that would ultimately spell their demise at the Church's hand—for how could there be relics of someone who supposedly ascended bodily into Heaven?

Much historical back-up and additional compelling examples of anomalies on the Shroud itself add weight to Dr Laidler's controversial hypothesis.

### THE END OF PRIVACY

by Reg Whitaker

Publisher: Scribe, Australia, 2000 (first pub. by The New Press, NY, USA, 1999)  
ISBN: 0-908011-46-6 (200pp tpb)

Price: A\$27.50; NZ\$39.95; US\$14.95  
Available: **Aust**—Scribe Publications, tel (03) 9349 5955, e-mail scribe@bigpond.net.au; **NZ**—Addenda, tel (09) 834 5511; **USA**—The New Press, tel (212) 629 8802

The surveillance state has become the surveillance society, argues Reg Whitaker, professor of political science at Toronto's York University, in *The End of Privacy*. Big Brother has merely outsourced his services to the nation-state with the availability of new surveillance technologies.

Whitaker rebukes the US National Security Agency for its use of the *Echelon* system in spying on European companies for US corporate advantage. Yet he underplays the less-well-publicised activities of the NSA in targeting individuals and groups deemed a "threat to national security" by the US and

"friendly governments". The main stage he sees as now dominated by transnational corporations intent on globalisation and invasion of cultural and personal space, yet tempered by global-scale activism only made possible by the very nature of the new technology. He cites the WTO Seattle electronic protests and the Zapatista techno-peasant revolt as examples of the powerful new trend in global Internet activism.

In the foreword (Australian edition only), Whitaker alerts us to the new Regulation of Investigatory Powers (RIP) Act in the UK, which will force ISPs to become informants and link in with MI5's new e-mail surveillance centre (Global News, 7/03-4, 7/06). There is a very real threat that Internet activism will soon be made illegal.

Whitaker sees that we'll have to redefine notions of protected space and find a balance between privacy and freedom of information rights versus corporate intrusion, but the picture is even bigger than he admits.

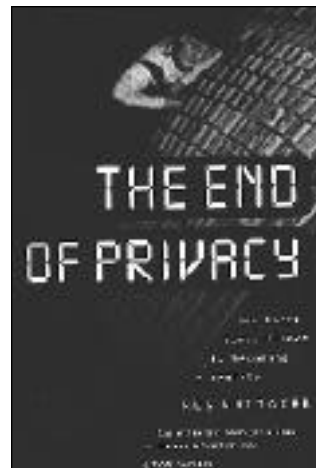





# REVIEWS

## BOOKS

### WELLNESS IN MENOPAUSE:

#### A Guide to Holistic Healing by Marylyn Meek

Publisher: Newleaf, Ireland, 2000

ISBN: 0-7171-0064-2 (288pp tpb)

Price: £10.99 + p&h

Available: **Ireland**—Newleaf/Gill & Macmillan, Dublin, tel +353 1 500 9500, fax +353 1 500 9599, website [www.gillmacmillan.ie](http://www.gillmacmillan.ie)

Rather than being a time of physical and emotional distress, menopause—that transition in a woman's life when she moves beyond her reproductive years—can be a time of coming into a greater understanding of personal power and wisdom.

UK author and spiritual/holistic healer Marylyn Meek, in *Wellness in Menopause*, encourages women to participate in their own healing and reconnect with their true self. She acknowledges that while each woman experiences menopause in her own way, every woman should aim to understand the process, treat it as a shared experience, try to accept it, take steps to ease the symptoms, pass through it—and emerge with a positive mental outlook, a healthy, active body, enhanced emotional awareness and greater knowledge of the whole self.

Meek's emphasis is on natural therapies to help the process. While she does discuss hormone replacement therapy (HRT), she cautions against using synthetic drugs: not only do they have adverse health effects, but ultimately they are disempowering.

The alternative treatments she describes include natural progesterone, aromatherapy,

Bach flower remedies, oriental medicine (including ayurvedic treatments, Chinese herbs, shiatsu, yoga and meditation), herbal medicine, homoeopathy and reflexology.

Meek also places strong emphasis on appropriate diet and exercise, and includes many case studies that speak reams for the benefits of a natural approach to menopause. She also has a lengthy section summarising common menopausal symptoms and a selection of appropriate holistic treatments.

This is an easy-to-follow, practical guidebook that will be appreciated by women who object to the indiscriminate use of synthetic hormones and are seeking natural alternatives to ease their transition.

### THE CRYSTAL SUN: Rediscovering a Lost Technology of the Ancient World by Robert Temple

Publisher: Century, UK, 2000

ISBN: 0-7126-7888-3 (558pp hc)

Price: A\$49.40; NZ\$69.95; £20.00;

NLGfn/a

Available: **Aust/NZ/UK**—Random House; **Eur**—NEXUS Office, tel +31 321 380558

Hundreds of examples of crystal and glass lenses have been dug up from archaeological sites and are on show at museums, yet scientists and academics tend to ignore them. That would mean admitting that knowledge of optics and lens-grinding technology existed in antiquity—which is at odds with textbook explanations of their discovery in Europe in mediaeval times.

Robert Temple, author of *The Sirius Mystery*, has spent 33 years on and off researching this underplayed part of history for his new book, *The Crystal Sun*. He has found examples of these lenses unearthed from Babylonian, Assyrian, Egyptian,

Greek, Minoan, Roman, Celtic, Chinese and Scandinavian civilisations. One famous example, the Layard lens held in the British Museum, was found in an 8th century BC Assyrian tomb and was purpose-shaped for an important person who was short-sighted.

Not only are there these exquisite examples, there are also artworks, texts and legends that describe the uses of lenses as eye-glasses, telescopes, microscopes, surveying tools, water-filled glass globe magnifiers, and light-focusing mirrors to make fire and fight wars. Archimedes' idea that saw the Roman fleet burn at Syracuse in the 3rd century BC was even recreated in 1973.

So why does science seem so blind to the idea of sophisticated technology existing in antiquity? Robert Temple is still answering that, but he suggests that past scholars made things worse when they mistranslated classical texts which they did not understand or whose contents did not fit with their world view. His book really is an eye-opener.

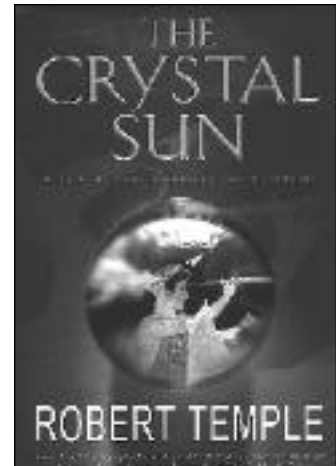

# REVIEWS



## BOOKS

### THE GYMPIE PYRAMID STORY

by Brett J. Green

Publisher: De Grene, Australia, 2000

ISBN: 0-9586878-2-X (148pp l/f pb)

Price: A\$35.00 inc. p&h

Available: **Australia**—De Grene Enterprises, 52 Red Hill Road, Gympie, Qld 4570, fax +61 (0)7 5482 3909, e-mail degrene@safeweb.com.au, website www.safeweb.com.au/~degrene

The Gympie and Cooloola regions of southeast Queensland are scattered (as are other parts of Australia) with anomalous stone ruins and artefacts which point to visitation if not settlement by various non-Aboriginal peoples over the last few thousand years. The most controversial artefact of all is the so-called Gympie Pyramid.

Amateur historian Brett Green has devoted much of the past 15 years to sorting the facts from the myths, conducting his own field research and talking with locals about their reminiscences and finds. Pulling all this together for his book, *The Gympie Pyramid Story*, he also summarises the findings of recent researchers such as Rex Gilroy and reprints material from the diaries of 18th-century European pioneers. One in particular, John Green, got to know local Aborigines and learn their languages and legends—many of which refer to "gods" who arrived from across the sea and erected structures of religious significance.

From an early photograph and reconstructed drawings, it seems that the pyramid was a hill with stone terrace-work, accessed through an inscribed stone archway, with a ceremonial megalithic stone installation at

the top. The inscriptions have some hieroglyphic elements, but they have commonalities with those found in the South Pacific, South America and elsewhere.

Green speculates on a host of extant artefacts in the light of voyages by Egyptians, Celts, Phoenicians, Arabs, Chinese, Incas, Pacific Islanders, ancient Dravidians/Tamils and more. He also shows that these visitors have left their linguistic stamps on local Aboriginal languages in surprising ways. The array of evidence for Australia's rich, alternative history up-ends the textbooks.

### PROOF OF VEDIC CULTURE'S GLOBAL EXISTENCE

by Stephen Knapp

Publisher: TWRN, USA, 2000

ISBN: 0-9617410-6-6 (342pp tpb)

Price: US\$14.95 + p&h

Available: **USA**—The World Relief Network, PO Box 15082, Detroit, MI 48215-0082, tel +1 (313) 331 3190

The missing link in our understanding of civilisation is the Vedic Aryan culture which thrived on the Indian subcontinent in antiquity and which influenced subsequent civilisations in Sumeria, China, Egypt and the Middle East, Europe and Britain, South-East Asia and as far away as the Americas.

Stephen Knapp, in *Proof of Vedic Culture's Global Existence*, delves into the history and traditional sources of the Vedas—that ancient body of sacred literature which many regard as the fount of the world's spiritual and cultural heritage. To set the record straight, he explains the true Sanskrit meaning of the word *Aryan* as "a way of life that aims at the elevation of everyone in society to a higher level of

consciousness". Some traditions have it that Vedic knowledge was given to humanity by the Supreme over a million years ago; others, in the scores of thousands of years ago. The *Rig-veda* refers to the Sarasvati River in the time of the Indus Valley civilisation—a river which scientists now believe stopped flowing around 8000 BC—so this has to be an ancient body of knowledge.

The Vedas also contain evidence of high-tech know-how, such as ion engines that powered flying craft. Could such inventions account for the vast global influence the Vedic Aryans supposedly had? Knapp says that at the base of many a temple, be it Sumerian, Persian, Hindu, Islamic or Christian, can be found Vedic foundations. Vedic Sanskrit influence is also obvious in world languages from the Indo-European to the Incan. We thus have some responsibility, Knapp urges, to protect what is left of Vedic culture, not just on the subcontinent but wherever on Earth it has touched.

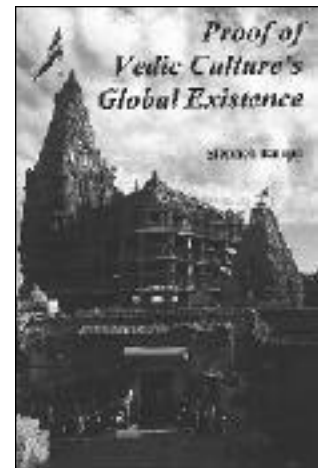



# REVIEWS

## BOOKS

### THE SHAMBALLA IMPACTS: Their Esoteric Astrology in World History by Phillip Lindsay

Publisher: Apollo, Australia, 2000  
ISBN: 1-876849-00-2 (207pp tpb)  
Price: A\$33.00 + p&h; NZ\$40.00 + \$3 p&h; US\$15.00 + s&h (details on website)  
Available: **Australia**—Apollo Publishing, PO Box 171, Newport Beach, NSW 2106, tel/fax +61 (0)2 9997 1242, e-mail apollo@easy.com.au, website www.easy.com.au/spicycle/ApolloPub.html; **NZ**—Triangle Centre, tel (04) 292 7181

Humanity is said to be poised to take a quantum evolutionary leap in these times, by aligning with the higher spiritual forces focused on this planet. According to information transmitted by Tibetan Master Djwhal Khul (DK) to Alice Bailey back in the 1920s–1950s, the year 2000 is particularly important. As author Phillip Lindsay explains in this well-produced handbook of distilled wisdom, the specific planetary alignments of May 2000 heralded the "fifth Shamballa impact direct to Humanity".

The Buddhist Kalachakra teaching or Ageless Wisdom regards the solar system as a living entity, the Solar Logos as having a destiny to fulfill, the planets as energy centres or chakras, and Shamballa as the "planetary head centre"—"the Centre where the Will of God is known". In *The Shamballa Impacts* (one of a series of DK/Bailey-inspired titles) Lindsay gives a brief history of Shamballa (located "near the Gobi Desert"), and explains the significance of the annual Moon-in-Taurus Wesak Festival,

when Shamballa energies are transmitted to the gathered Masters of Wisdom and indirectly to Humanity. He describes the three Shamballa impacts of historical times—1825, 1975 and 2000—where energy is said to have been released directly to Humanity, and illustrates their cosmic significance with zodiac charts drawn and interpreted according to esoteric or soul-centred astrology and the principles of the Seven Rays.

The subtle effects of the fifth Shamballa impact of May 2000 will be felt for years to come, says Phillip, with the reminder that it's up to Humanity to decide whether to plunge into darkness or synthesise the teachings so as to move up the spiral of consciousness into the next initiation cycle.

### REMOTE VIEWING SECRETS by Joseph McMoneagle

Publisher: Hampton Roads, USA, 2000  
ISBN: 1-57174-159-3 (296pp tpb)  
Price: A\$36.30; NZ\$46.95; £11.95; NLGfn/a; US\$14.95

Available: **Aust**—Gemcraft, tel (03) 9888 0111; **NZ/UK/Europe**—NEXUS offices; **USA**—Hampton Roads Publishing, tel (804) 296 2772, website www.hrpub.com

In his third book, *Remote Viewing Secrets*, Joe McMoneagle compares the discipline and science of accurate remote viewing with the physical and spiritual aspects of the martial arts. He's even trademarked his own "way" of remote viewing as "RV'do".

McMoneagle, author of *Mind Trek* and *The Ultimate Time Machine* (see 6/02), participated in the US Army's top-secret RV program, Project *Stargate*, and has worked for the past 15 years as a research associate and subject at SRI International's Cognitive Sciences Lab (CSL), which first put RV on

the map. Anyone who has been part of CSL or *Stargate* has their own version of events, so he points readers to websites that cover RV history, personalities and politics in more detail. He has since set up his own group, Intuitive Intelligence Applications.

Through this handbook, McMoneagle aims to provide the correct information for those interested in fine-tuning their RV abilities in practice. He defines remote viewing, describes who makes a successful viewer, and explains the differences between various protocols, methodologies and styles used to collect and process information. He discusses training/learning regimens, target selection, record keeping, RV applications as well as ethics and privacy issues.

McMoneagle also examines some of the strange characteristics of RV, e.g., geomagnetic disruptions or time factors which may disturb or enhance cognitive accuracy. That he also advises when to quit, if RV is really not working for you, speaks for his serious approach to this discipline.

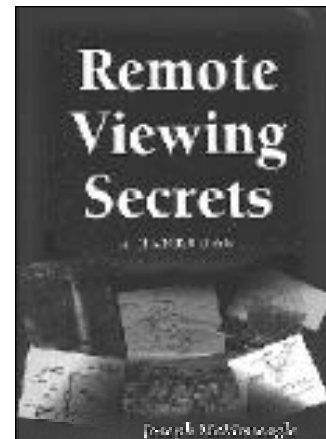

# REVIEWS



## BOOKS

### OUR EVOLUTION

by **Waldo Vieira, MD**

Publisher: IIPC, Brazil, 1999

ISBN: 85-86019-42-9 (183pp tpb)

Price: £8.00 + £3 p&h; US\$11.95;

C\$20.00; US\$22.00 inc. p&h to Aust/NZ

Available: **UK**—International Institute of

Projectology and Conscientology, tel +44

020 7723 0544, e-mail London@iipc.org;

**USA**—IIPC-NY, tel (212) 869 4595, e-mail

newyork@iipc.org, website www.iipc.org

This next book by Brazilian consciousness researcher Dr Waldo Vieira to be translated into English is not so much an out-of-body training manual but a guide to the evolution of consciousness. Dr Vieira has spent much of the last 40 years exploring the complexities and nuances of consciousness and multidimensional reality via out-of-body projection (see review in 7/03).

We all inhabit these extraphysical realms of relative truth, though we may not be consciously aware that we do, but with discipline and will we can learn to access myriad layers of knowledge to assist in our evolution as beings with ego, intelligence, soul and spirit. Dr Vieira asks us to reflect on this primary affirmation and challenge: if you think self-knowledge demands a great deal of effort, try to evolve with ignorance.

His book, *Our Evolution*, is full of wise answers—based on personal experience—to the fundamental questions that plague humanity: Who am I? What am I? Where am I from? Why am I here? Where am I going? He confirms that soul evolution is a reality, that soul groups incarnate together to fulfill specific purposes, that we prepare in

advance for the life we are reborn into, and that the personality is not lost at death but also evolves. Dr Vieira regards it as fact that our consciousness is shaped by an accumulation of life-after-life experiences.

The terminology Dr Vieira uses requires some getting used to—every experienced out-of-body traveller seems to have different expressions for the same territories—but the extensive glossary is helpful if you get lost. This is profound yet practical material to help optimise performance on all levels in this life—and way beyond.

### THE JESUS MYSTERIES: Was the Original Jesus a Pagan God?

by **Timothy Freke and Peter Gandy**

Publisher: Thorsons, UK, 1999

ISBN: 0-7225-3677-1 (424pp pb)

Price: A\$16.95; NZ\$24.95; £6.99

Available: **Aust/NZ/UK**—Harper Collins, website www.thorsons.com

The historical Jesus never existed, and what passes for "gospel truth" in the New Testament was a Gnostic rewriting of ancient Pagan god-man death and resurrection myths, conclude authors Timothy Freke and Peter Gandy in *The Jesus Mysteries*.

These myths, or the secret teachings of the ancient mystery schools, were placed in a Jewish historical context at the beginning of the Piscean Age but were hijacked by what became the "Literalist" school, which morphed into the Church of Rome and ultimately into a politically expedient as a state religion for Constantine and his empire.

The same "Jesus mystery" had its precedents in the Egyptian Osiris, the Greek Dionysus, the Persian Mithras, the Syrian Adonis, the Roman Bacchus and other god-man figures, though how far back it goes

into antiquity the authors do not say.

In the Hellenised Mediterranean world of the first few centuries BCE, the Alexandrian Jews, in particular the Therapeutae, were keen to incorporate the essentials of these mysteries into their scriptures, and a Gnostic tradition sprang up before any historical Jesus was supposed to have lived, Freke and Gandy contend. A Jewish Messiah was deemed to be the ideal persona to portray an Osiris-Dionysus figure, and so he was written into history, fulfilling the prophecies, by the 2nd century CE in Alexandria. The story was meant to be a spiritual allegory; but by placing it in a time frame it was inevitable that future generations would interpret it as exoteric truth. The rest is (tragic) history!

Freke and Gandy don't deny that their conclusions are utterly challenging to Christian (and Jewish) belief systems, but feel that their message will strengthen the resolve of those who seek true spiritual gnosis.

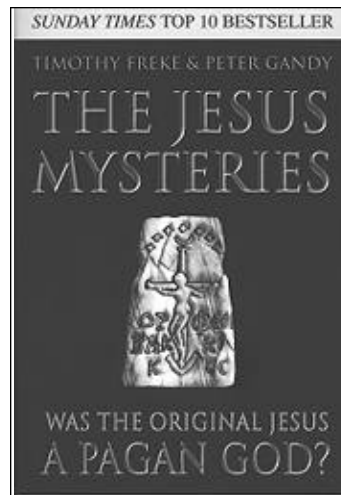



# REVIEWS

## BOOKS

### THE CANCER CONSPIRACY: What You Must Know About The Worst Plague in Human History by Toni Jeffreys, PhD

Publisher: Crows Nest Books, NZ, 2000  
ISBN: 0-959-7892-1-9 (333pp tpb)  
Price: NZ\$35; A\$35 economy air to Aust;  
US\$25 to USA/Canada; £18 to UK/Europe  
Available: **New Zealand**—Crows Nest  
Books, PO Box 607, Warkworth, NZ  
1241, fax +64 (0)9 425 6692, e-mail  
crowsnestbooks@clear.net.nz

What started out as a brief defence of the parents of Liam Holloway in New Zealand, to put a stop to the chemotherapy treatment of their son's cancer, grew into a megawork for Toni Jeffreys, PhD.

Subtitled "What you must know about the worst plague in human history", *The Cancer Conspiracy* looks at what cancer is, why so many thousands of people get it, and how it can be prevented as well as cured—if only a few problems with modern medicine and the

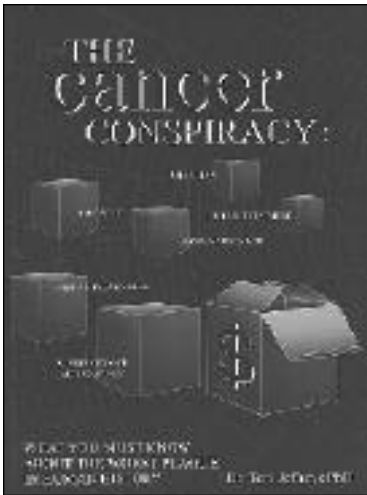

legislative system can be overcome.

Jeffreys, author of *Your Health At Risk* (see 6/05), is an advocate of freedom of choice in health care. Thus, the very idea that governments would want to legislate against individual freedom of choice is anathema to her. Medicine still can't explain what cancer is, yet the system promotes invasive treatments, like chemotherapy, which have high failure rates compared with successful alternative therapies which it seems hellbent on stamping out.

The New Zealand experience is a microcosm for what's happening all over the world: fraudulent research and dubious trial procedures; the unwillingness of doctors and health administrators to acknowledge the role of environmental and dietary factors in

the soaring cancer rates (e.g., pesticide residues ingested in sprayed foods); and the machinations of power-players from big business and politics.

The "cancer conspiracy" has a long and infamous history, but that doesn't mean we can't do something about it. Education is the key to ensuring sufficient numbers of people demand and secure their right to use the preventive regimens and treatments of their choice. After all, Dr Jeffreys implores, why should a vast deception cost you your life?

### THE MASTER KEY by Charles F. Haanel

Publisher: Master Key Publishing, Qld, Australia, 2000 (first published 1916)  
ISBN: n/a (352pp tpb)

Price: A\$33.00 + A\$7 p&h in Aust; + A\$8.50 econ. air to NZ; + A\$11 to S/E Asia; + A\$14 to UK/Eur/Sth Africa; + A\$12.50 to USA/Canada

Available: **Australia**—Master Key Publishing, PO Box 1581, Southport BC, Qld 4215, tel/fax +61 (0)7 5532 4516, e-mail thekey@themasterkey.com.au, website www.themasterkey.com.au

Craig Brown had been on a spiritual journey for 20 years when he stumbled upon a long-forgotten book that would change his life. Titled *The Master Key*, it was full of arcane yet practical wisdom and written by one Charles F. Haanel in 1912 (published in 1916 and again in 1933).

Brown has been unable to unearth much about Haanel, other than he was born in Ann Arbor, Michigan, in 1866 and died in 1949, was a businessman, an author and a member of the American Scientific League and American Society of Psychical Research, among other groups. Brown also learned that the book had been banned, so it was a rare find. Inspired by Haanel's wise words, Brown decided to sink all his funds into republishing this long-lost work.

In 24 parts, *The Master Key* sets out the fundamental principles of life and creative living, as Haanel came to understand and apply them. Basic to his teaching is the correct development and use of mental power—the key to truly creative power and action, harmony and health, love and happiness, and abundant possibilities. Each part is meant to be studied like a correspondence course lesson, but this is also a book that can be opened at random for whatever gem of advice your eyes happen to fall upon.

This is age-old wisdom, written by someone who could perceive and tap into Universal Mind but who seems to have no particular allegiance to any specific system of knowledge. Haanel's numbered, commonsense messages still have a freshness 88 years after they were first assembled.

# REVIEWS



## BOOKS

### **pH: YOUTHING, NOT AGEING**

by **Harald W. Tietze**

Publisher: Harald W. Tietze Publishing, NSW, Australia, 2000

ISBN: 1-876173-24-6 (125pp pb)

Price: A\$12.95 inc. p&h; A\$15.00 overseas p&h; NZ\$15.00; US\$12.95

Available: **Australia**—Harald W. Tietze Publishing, PO Box 34, Bermagui, NSW 2546, tel (02) 6493 4552, fax (02) 6493 4900, e-mail tietzepub@sci.net.au, website [www.sci.net.au/tietzepub](http://www.sci.net.au/tietzepub); **New Zealand**—Naranja Developments, tel (09) 478 2118; **South Africa**—New Horizon Distributors, tel +27 21 683 0360; **USA**—Beekman Publishers, tel (914) 679 2300

The main obstacle to living a healthier, longer life is organic waste build-up in the body's tissues and joints, says health oracle Harald Tietze in his latest book, *pH: Youthing, Not Ageing*. The most effective way to deal with it, to detoxify the system, is to ingest ionised alkaline water—preferably 1.5 litres per day for maximum beneficial effect, but not within half an hour either side of eating, he says, so as not to dilute the correct pH factor of the stomach acids.

Tietze stresses that water is not a food but a carrier, and ionised alkaline water is the ideal medium for helping the body dispose of acidic waste products—and regardless of how healthy one's diet is, there are still organic wastes to be purged from the system. Such substances only hasten the ageing process; to be rid of them is to be on the path of youthful health and vitality. But this is a path that requires long-term dedication; it's not about short-term fixes.

Tietze explains in simple terms the science of the pH factor and how it relates to balance in health, the differing pH levels within the bodily fluids, and the acid or alkali-forming qualities of various foods.

Processed foods are very acid-forming, yet even some alkaline foods can be, particularly if they're non-organic. Environmental factors such as electropollution and Earth rays can also have acid-intensifying effects.

Interestingly, there is a place for ionised acidic water, but it is usually for external use or for treating particular disease conditions. Tietze describes a range of uses for both acid and alkaline ionised water as well as how to make your own supplies using a basic electrolytic process. Through this book, he identifies a key health factor which hitherto has been underappreciated.

## VIDEO

Reviewed by **Duncan Roads**

### **WHAT HAPPENED ON THE MOON?**

**An Investigation into Apollo**

Presented/narrated by Ronnie Stronge  
Produced 2000 (PAL/VHS, 222mins) for Aulis Publishers, 20 Paul Street, Frome, BA11 1DX, UK, tel/fax +44 020 7794 4759, website [www.aulis.com](http://www.aulis.com)

Price: £18.50 including p&h in UK;

£22.00 airmail to Australia

Available: **UK**—NEXUS Magazine, 55 Queens Road, East Grinstead, W. Sussex, RH19 1BG, tel 01342 322854

**USA**—Adventures Unlimited Press, PO Box 74, Kempton IL 60946, tel (815) 253 6390, fax (815) 253 6300, website [www.wexclub.com/aup](http://www.wexclub.com/aup)

While most NEXUS readers have heard of the discrepancies involving our visits to the Moon, many would not be in a position to be able to decide for themselves as to the authenticity of the allegations.

Look no further! For the first time (to my knowledge) armchair researchers can be treated to an absorbing documentary which goes into painstaking detail over discrepancies in the photographic and film records.

Featuring whistleblowers and industry experts, this documentary uses excellent visuals to explain in layperson's terms the serious flaws in many NASA photos of astronauts on the Moon as well as in transit.

Topics in Part 1 include analysis of the type of film used; the cameras; the cross-hairs on the photos; non-parallel shadows; Moon rocks with letters written on them; light-source discrepancies; continuity flaws between what was photographed and what was filmed; anomalous light sources; and strange scaling of background "mountains".

Part 2 explores the environmental discrepancies between what is known and what is possible. Solar radiation, Van Allen belts, X-rays and micrometeorites reveal more questions than answers. Part 3 is an investigation into rockets and propulsion systems. It explores the history of rocket scientists, starting in pre-WWII Nazi Germany.

It is very difficult to explain away or dismiss the evidence compiled in this documentary. The producers, to their credit, have included answers from the "experts", but the trouble now is that the experts sound desperate to maintain some semblance of dignity and credibility in the face of overwhelmingly contradictory information.



# REVIEWS

## MUSIC

Reviewed by Richard Giles

### SONGMAN

by Nomad

Producer: Nomad for AMI, USA, 1999 (43mins)

Distributors: **Australia**—MRA, tel (07) 3849 6020; **USA**—AMI, tel (212) 253 1567, website [www.ausmusic.cc](http://www.ausmusic.cc)

Several years ago, Nomad had a smash alternative album hit, titled *Nomad*, which just sold and sold. Their new release, *Songman*, has the same entrancing tribal sound and the same faraway call to the listener to an ancient cultural celebration of song and dance. The origins of the album are in recordings made in Arnhem Land in the mid-1990s with David Gulpilil's community in Ramingining. An exciting, haunting and satisfying album.

### UNDER SOUTHERN SKIES

by Tony O'Connor

Producer: Jacqui O'Connor for Studio Horizon, Qld, Aust, 2000 (55mins)

Distributors: **Aust**—Studio Horizon Distribution, tel (07) 5478 5215, [www.studiohorizon.com](http://www.studiohorizon.com); **UK**—New Life 2000, tel 01442 251430; **USA**—Studio Horizon North, tel (902) 302 5370

Tony O'Connor is a phenomenon both in Australia and internationally, and he has produced a number of gold and platinum albums in the last decade. The ambient sound we've come to know and love as the recognisable signature of Tony's work has changed. It's good to hear some different production techniques on *Under Southern Skies*, and the fresh, orchestral style which Tony has adopted here is both warming and encouraging. Recommended.

### DANCE INTO ETERNITY

Selected Pieces 1987-1998

by Omar Faruk Tekbilek

Producer: John Schaefer for Celestial Harmonies, AZ, USA, 2000 (77mins)

Distributors: **Aust**—Arts Distribution, tel (02) 9905 9435; **USA**—Celestial Harmonies, tel (520) 326 4400, website [www.harmonies.com](http://www.harmonies.com)

If you've heard Omar Faruk Tekbilek's music before, you need no introduction to this amazing man's work. His emotional, mystical link with his Turkish origins allows him to produce the most extraordinary music. In 1988, his first international album, *Süleyman the Magnificent* (with Brian Keane) launched him as a world-respected figure. *Dance Into Eternity* com-

prises collected works from eight albums released by Celestial Harmonies. Some wonderful tracks like "Crescent Moon" grace this exciting, must-have compilation.

### FENG SHUI: The Eightfold Path

by Chinmaya Dunster

Producer: Chinmaya Dunster for New Earth Records, USA, 2000 (46mins)

Distributors: **Aust**—New World Music, tel (02) 9565 4522, 1800 628 823; **UK**—New World Music, tel 0198 678

1682; **USA**—New Earth Records, tel (505) 466 2471, [www.newearthrec.com](http://www.newearthrec.com)

UK-born Chinmaya Dunster studied classical guitar and then moved on to the Indian classical instrument, the sarod. On *Feng Shui*, he attempts to capture the vibration of the eight sectors in a house using the Feng Shui compass method. Chinmaya relates each compass direction to one branch of the Eightfold Path of Behaviour as enunciated by the Buddha. The music is very calming, with its mix of an Eastern and an almost traditional English sound. A pleasant ambience makes this a charming CD.

### NIYA YESH

by Axiom of Choice

Producer: Axiom of Choice for Narada Productions, USA, 2000 (58mins)

Distributors: **Aust**—EMI/Virgin, tel (07) 3252 7744; **USA**—Narada Music, tel (414) 961 8350, [www.narada.com](http://www.narada.com)

Axiom of Choice is a collective of musicians bringing together Persian, Indian and Western sounds with some beautiful vocalisations from classical Persian-trained Mamak Khadem. With the slow and careful compositions of Loga Ramin Torkian, mixing classical Iranian music with Indian and Western influences, this is a special album of deeply moving, open-hearted world music. Mamak Khaden's vocals are woven hymns to poignant love and pain. These are excellent, precious sounds.

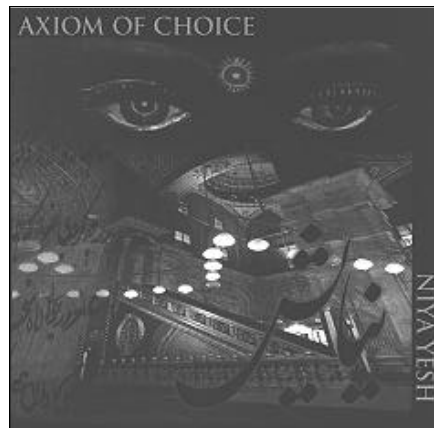





Continued from page 39

homogeneity in trials and identification of the unique features of SBS as opposed to other abuse, other medical conditions and normals.

- Lack of useful and specific laboratory or other markers proven to identify SBS.
- Poor definition and quantification of the social and family risk factors to provide guidance on likelihood of abuse for a given set of circumstances.
- There is a strong need for a checklist or other diagnostic or management tool to assess cases and to quantify index of suspicion of shaking."

A paper in the *British Medical Journal* concluded:<sup>16</sup>

"Subdural haemorrhage is common in infancy and carries a poor prognosis; three quarters of such infants die or have profound disability. *Most* cases are due to child abuse, but in a few the cause is *unknown*." [Author's emphasis added.]

The authors of the paper believe that the clinical investigation of such children should include:

- a full, multidisciplinary, social assessment;

- an ophthalmic examination;
- a skeletal survey supplemented with a bone scan or a skeletal survey, repeated at around 10 days;
- a coagulation screen;
- a computed tomography or magnetic resonance imaging.

However, according to Dr Mark Donohoe:

"There is an urgent need for properly controlled, prospective trials into SBS, using a variety of controls. Until such studies are complete, published and replicated, the current opinion on the link between SDH/RH and SBS cannot be sustained."

### RESPONSIBILITIES OF THE LEGAL AND MEDICAL PROFESSIONS

The correct diagnosis of Shaken Baby Syndrome is a problem for those being accused of this syndrome around the world. The cases mentioned are only a small number that have occurred over the past few years.

It is hard to imagine the distress, confusion and despair suffered by the accused and their families, especially those who have been jailed for life for a crime they

claim they did not commit.

Juries and lawyers rely heavily on what medical experts tell them. If medical experts are guilty of grossly misleading a court of law by providing skewed evidence from inadequate medical research on SBS, then innocent individuals are suffering unnecessarily. Let us hope that the SBS medical experts comprehend that they are not infallible and realise the untold human tragedy that can occur if they are wrong.

### Glossary

The key terms in the identification of SBS are alleged to be:<sup>17</sup>

- Cerebral oedema: fluid collecting in the brain, causing tissue to swell.
- Haematoma: a localised accumulation of blood in tissues as a result of haemorrhaging.
- Haemorrhage: a condition of bleeding, usually severe.
- Retinal haemorrhage (RH): bleeding of the retina, a key structure in vision located at the back of the eye.
- Subdural Haematoma (SDH): a localised accumulation of blood, sometimes mixed with spinal fluid, in the space of the brain beneath the membrane covering called the dura matter.

Continued on page 82

## Shaken Baby Syndrome or Adverse Vaccine Event?

Continued from page 81

### Endnotes

1. *Gale Encyclopedia of Medicine* (Olendorf, Jeryan, Boyden, editors), Gale Research, Detroit, MI, vol. 4, 1999, p. 2604.
2. "Abuse and Neglect of Children", *Nelson Textbook of Pediatrics* (Behrman, Kliegman, Jenson, eds), W.B. Saunders Co., Philadelphia, PA, 2000, 16th edition, chapter 35, p. 113.
3. Baker, Mitzi, "That was no accident: Biochemical markers could one day help identify battered children", *New Scientist*, 28 November 1998, p. 21.
4. *The Australian Immunisation Procedures Handbook*, National Health and Medical Research Council, 5th edition, October 1994 and revised 5th edition, 1995.
5. *Regina v Scott Warren Walters*, Supreme Court of New South Wales, Criminal Division, No. 70031 of 1998.
6. Behan, Peter O., MD, FACP, FRCP (Professor of Neurology, Glasgow University, Scotland), "Report on the Neurological Complications of Pertussis Vaccination in Children", August 1995; and letter from Professor Behan to Sydney solicitors, dated 13 October 1993, regarding a vaccine damage claim.
7. Dr Mark Donohoe's research on Shaken Baby Syndrome, prepared for the case of *Regina v Scott Warren Walters*, heard in Sydney, Australia, in 1998.
8. Kalokerinos, Archie, MD, *Every Second Child*, Pivot/Health Books/Keats Publishing, CT, USA, 1981 (first published by Thomas Nelson Australia Ltd, 1974), ISBN 0-87983-250-9.
9. Information provided to the writer by the father of Baby A. in written correspondence and history, taken by Harold E. Buttram, MD, and F. Edward Yazbak, MD, of the Woodlands Healing Research Center, Quakertown, PA, USA, dated 25 May 2000.
10. Driscoll, Margarette, "Shadow of Doubt", *Sunday Times News Review*, UK, 28 November 1999. The article reports that Christopher was vaccinated on the day before his death; but Dr Viera Scheibner has learned that the boy was vaccinated 23 days before he died—one of the critical days, according to her studies linking SIDS (sudden infant death syndrome) with vaccinations.
11. *New South Wales Children (Care and Protection) Act 1987*, No. 54.
12. *ibid.*, section 23, pp. 30-31.
13. *The Australian Immunisation Procedures Handbook*, 7th edition, March 2000, pp. 22, 259; also, Drs Gordon Ada and David Isaacs, *Vaccination: The Facts, The Fears, The Future*, Allen & Unwin, Sydney, 2000, pp. 91, 94, ISBN 1-86508-223-6.
14. Commonwealth Department of Health and Aged Care, *Communicable Diseases Intelligence Bulletins*: 21(20):313, 2 October 1997; 21(23):364, 25 December 1997; 22(7):146, 9 July 1998; 22(10):234, 1 October 1998; 23(1):34, 21 January 1999; 23(9):255, 2 September 1999.
15. Dr Mark Donohoe's research on Shaken Baby Syndrome, prepared for the case of *Regina v Scott Warren Walters*, *ibid.*
16. Jayawant, S., Rawlinson, A., Gibbon, F., Price, J., Schulte, J., Sharples, P., Sibert, J.R., Kemp, A.M., "Subdural haemorrhages in infants: population-based study", *British Medical Journal* 317:1558-1561, 5 December 1998.
17. *Gale Encyclopedia of Medicine*, *op. cit.*

### About the Author:

Maureen Hickman, JP, has been a para-legal in Sydney law firms for over 25 years and currently works part-time at Carters Law Firm. She is the author of *Vaccination: The Right Choice?* (reviewed in NEXUS 7/04, June-July 2000).

### Editor's Note:

For additional background information, refer to "Shaken Baby Syndrome: The Vaccination Link" by Viera Scheibner, PhD, published in NEXUS 5/05, August-September 1998.

Continued from page 58

### Great Civilisations Meet their Doom

Incredible as it may seem, archaeologists have found evidence in India and Pakistan, indicating that some cities were destroyed in atomic explosions. When excavations of Harappa and Mohenjo-Daro reached the street level, they discovered skeletons scattered about the cities, many holding hands and sprawling in the streets as if some instant, horrible doom had taken place. People were just lying, unburied, in the streets of the city. And these skeletons are thousands of years old, even by traditional archaeological standards. What could cause such a thing? Why did the bodies not decay or get eaten by wild animals? Furthermore, there is no apparent cause of a physically violent death.

These skeletons are among the most radioactive ever found, on par with those at Nagasaki and Hiroshima. At one site, Soviet scholars found a skeleton which had a radioactive level 50 times greater than normal.<sup>26</sup>

The Russian archaeologist A. Gorbovsky mentions the high incidence of radiation associated with the skeletons in his 1966

book, *Riddles of Ancient History*.<sup>27</sup> Furthermore, thousands of fused lumps, christened "black stones", have been found at Mohenjo-Daro. These appear to be fragments of clay vessels that melted together in extreme heat.

Other cities have been found in northern India that show indications of explosions of great magnitude. One such city, found between the Ganges and the mountains of Rajmahal, seems to have been subjected to intense heat. Huge masses of walls and foundations of the ancient city are fused together, literally vitrified! And since there is no indication of a volcanic eruption at Mohenjo-Daro or at the other cities, the intense heat to melt clay vessels can only be explained by an atomic blast or some other unknown weapon.<sup>28, 29, 30</sup> The cities were wiped out entirely.

If we accept the Lemurian Fellowship stories as fact, then Atlantis wanted to waste no more time with the Priest-Kings of Rama and their mental tricks. In terrifying revenge, they utterly destroyed the Rama Empire, leaving no country even to pay tribute to them. The areas around the cities of Harappa and Mohenjo-Daro have also been desolated in the past, though

agriculture takes place to a limited extent in the vicinity today.

It is said in esoteric literature that Atlantis at the same time, or shortly afterwards, also attempted to subjugate a civilisation extant in the area of the Gobi Desert, which was then a fertile plain. By using so-called scalar wave weaponry and firing through the centre of the Earth, they wiped out their adversaries—and possibly did themselves in at the same time!

Much speculation naturally exists in connection with remote history. We may never actually know the complete truth, though ancient texts still in existence are certainly a good start.

Atlantis met its own doom, according to Plato, by sinking into the ocean in a mighty cataclysm—not too long after the war with the Rama Empire, I imagine.

Kashmir is also connected with the fantastic war that destroyed the Rama Empire in ancient times. The massive ruins of a temple called Parshaspur can be found just outside Srinagar. It is a scene of total destruction. Huge blocks of stone are scattered about a wide area, giving the

Continued on page 84

Continued from page 83

impression of explosive annihilation.<sup>31</sup> Was Parshaspur destroyed by some fantastic weapon during one of the horrendous battles detailed in the *Mahabharata*?

Another curious sign of an ancient nuclear war in India is a giant crater near Bombay. The nearly circular 2,154-metre-diameter Lonar crater, located 400 kilometres northeast of Bombay and aged at less than 50,000 years old, could be related to nuclear warfare of antiquity. No trace of any meteoric material, etc., has been found at the site or in the vicinity, and this is the world's only known "impact" crater in basalt. Indications of great shock (from a pressure exceeding 600,000 atmospheres) and intense, abrupt heat (indicated by basalt glass spherules) can be ascertained from the site.

Orthodoxy cannot, of course, concede nuclear possibilities for such craters, even in the absence of any material meteorite or related evidence. If such geologically recent craters as the Lonar are of meteoric origin, then why don't such tremendous meteorites fall today? The Earth's atmosphere 50,000 years ago probably was not

much different from today's, so a lighter atmosphere cannot be advanced as an hypothesis to explain an immense-sized meteorite, which of course would be considerably reduced by heat oxidation in a gaseously heavier atmosphere. A theory was advanced by American space consultant Pat Frank, to the effect that some of the huge craters on the Earth may be scars from ancient nuclear explosions!<sup>32</sup>

The echoes of ancient atomic warfare in southern Asia continue to this day, with India and Pakistan currently threatening each other. Modern India is proud of its nukes, likening them to "Rama's Arrow". Similarly, Pakistan would love to use its Islamic atomic bombs on India. Ironically, Kashmir, possibly the site of an earlier atomic war, is the focus of this conflict. Will the past repeat itself in Pakistan and India?

There is always the possibility that this has all happened before. *Déjà vu!*

### Endnotes

18. Keller, Werner, *The Bible As History*, Hodder & Stoughton, London, 1956.
19. Lewis, L.M., *Footprints on the Sands of Time*, Signet Books, New York, 1975.
20. Service, Alistair, *Lost Worlds*, Arco

Publishing, New York, 1981.

21. *ibid.*
22. Kolosimo, Peter, *Timeless Earth*, University Press, Secaucus, New Jersey, 1974.
23. Reader's Digest, *The World's Last Mysteries*, Reader's Digest Association, Inc., Pleasantville, New York, 1976.
24. Berlitz, Charles, *Mysteries of Forgotten Worlds*, Doubleday, New York, 1972.
25. *ibid.*
26. *ibid.*
27. Gorbovsky, A., *Riddles of Ancient History*, Soviet Publishers, Moscow, 1966.
28. Kolosimo, *ibid.*
29. Tomas, Andrew, *We Are Not the First*, Souvenir Press, London, 1971.
30. Gorbovsky, *ibid.*
31. Childress, David Hatcher, *Lost Cities of China, Central Asia & India*, Adventures Unlimited Press, Stelle, Illinois, 1991.
32. Collins, Robin, *Laserbeams From Star Cities*, Sphere Books, London, 1971.

### About the Author:

David Hatcher Childress is an explorer, publisher and author of more than 15 books on lost civilisations and science as well as on free energy, antigravity and UFOs. He is a regular speaker on the conference circuit and a sought-after guest on US radio talk shows and TV specials.

This article is extracted from his new book, *Technology of the Gods: The Incredible Sciences of the Ancients* (Adventures Unlimited Press), reviewed in NEXUS 7/05.